

RACE SIGNALS

The meanings of visual and sound signals are stated below. An arrow pointing up or down (↑↓) means that a visual signal is displayed or removed. A dot (•) means a sound; five short dashes (-----) mean repetitive sounds; a long dash (—) means a long sound. When a visual signal is displayed over a class flag, the signal applies only to that class.

Postponement Signals

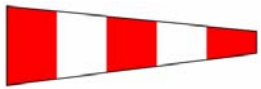

↑••• ↓•

AP Races not started are *postponed*. The warning signal will be made 1 minute after removal unless at that time the race is *postponed* again or *abandoned*.

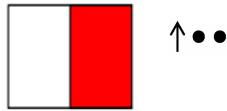
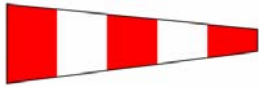

↑•••

AP over H Races not started are *postponed*. Further signals ashore.

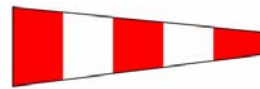

↑•••

AP over A Races not started are *postponed*. No more racing today.



Pennant 1 ↑••• ↓•

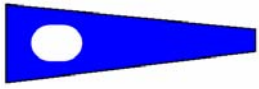

Pennant 2 ↑••• ↓•

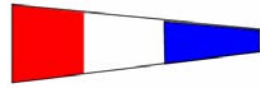

Pennant 3 ↑••• ↓•



Pennant 4 ↑••• ↓•

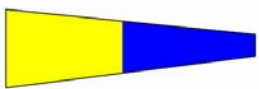

Pennant 5 ↑••• ↓•



Pennant 6 ↑••• ↓•

AP over a numeral pennant 1-6 *Postponement* of 1-6 hours from the scheduled starting time.

Abandonment Signals



↑•••• ↓•

N All races that have started are *abandoned*. Return to the starting area. The warning signal will be made 1 minute after removal unless at that time the race is *abandoned* again or *postponed*.



↑••••

N over H All races are *abandoned*. Further signals ashore.



↑••••

N over A All races are *abandoned*. No more racing today.

Preparatory Signals

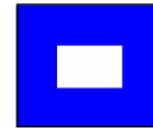

↑• ↓—

P Preparatory signal.

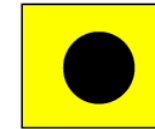

↑• ↓—

I Rule 30.1 is in effect.



↑• ↓—

Z Rule 30.2 is in effect.



↑• ↓—

Black flag. Rule 30.3 is in effect.

Recall Signals



↑•

X Individual recall.

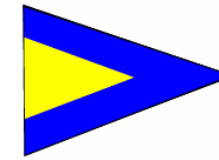

↑••• ↓•

First Substitute General recall. The warning signal will be made 1 minute after removal.

Course Change Signals

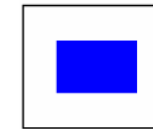

↑•••

S The course has been shortened. Rule 32.2 is in effect.



C The position of the next *mark* has been changed.

Other Signals



↑•

L Ashore: A notice to competitors has been posted. Afloat: Come within hail or follow this boat.



M The object displaying this signal replaces a missing *mark*.



↑•

Y Wear personal buoyancy.



(no sound)

Blue flag or shape. This race committee boat is in position at the finishing line.

**THE
RACING RULES
OF
SAILING**

for 2005–2008

**WINDSURFING
COMPETITION RULES**

**International Sailing Federation
International Windsurfing Association**

CONTENTS

	Race Signals	<i>Inside front cover</i>
	Introduction	5
	Basic Principle	7
	Windsurfing Competition	7
Part 1	Fundamental Rules	8
Part 2	When Boards Meet	10
Part 3	Conduct of a Race	16
Part 4	Other Requirements When Racing	27
Part 5	Protests, Redress, Hearings, Misconduct and Appeals	31
Part 6	Entry and Qualification	42
Part 7	Race Organization	44
	Appendices	
A	Scoring	47
F	Appeals Procedures	53
G	Identification on Sails	55
H	Weighing Clothing and Equipment	60
J	Notice of Race and Sailing Instructions	61
K	Notice of Race Guide	66
L	Sailing Instructions Guide	73
M	Recommendations for Protest Committees	89
N	International Juries	94
	Definitions	97

INTRODUCTION

The Windsurfing Competition Rules has been extracted from *The Racing Rules of Sailing* and adapted to windsurfing. It includes two main sections. The first, Parts 1–7, contains rules that affect all competitors. The second, Appendices A–N, provides details of rules and recommendations.

Revision The racing rules are revised and published every four years by the International Sailing Federation (ISAF), the international authority for the sport. This edition becomes effective on 1 January 2005. Marginal markings indicate important changes to Parts 1–7 and the Definitions of the 2001–2004 edition. No changes are contemplated before 2009, but any changes determined to be urgent before then will be announced through national authorities and posted on the ISAF website (www.sailing.org).

ISAF Codes The ISAF Eligibility, Advertising and Anti-Doping Codes (Regulations 19, 20 and 21) are referred to in the definition *Rule* but are not included in this book because they can be changed at any time. New versions will be announced through national authorities and posted on the ISAF website.

Cases The ISAF publishes interpretations of the racing rules in *The Case Book for 2005–2008* and recognizes them as authoritative interpretations and explanations of the rules. This publication is available on the ISAF website.

Terminology A term used in the sense stated in the Definitions is printed in italics or, in preambles, in bold italics (for example, *racing* and ***racing***). ‘Board’ means a sailboard and the competitor on board; when a board meets a boat, it means ‘boat’ as appropriate ‘Race committee’ includes any person or committee performing a race committee function. Other words and terms are used in the sense ordinarily understood in nautical or general use.

Appendices Each appendix is identified by a letter. A reference to a rule in an appendix will contain the letter and the rule number (for example, ‘rule A1’). There is no Appendix I or O, and Appendices B, C, D, E and P are omitted from the windsurfing rules.

Changes to the Rules The prescriptions of a national authority, class rules or the sailing instructions may change a racing rule only as permitted in rule 86.

Changes to National Authority Prescriptions A national authority may restrict changes to its prescriptions as provided in rule 87.

BASIC PRINCIPLE

SPORTSMANSHIP AND THE RULES

Competitors in the sport of sailing are governed by a body of *rules* that they are expected to follow and enforce. A fundamental principle of sportsmanship is that when competitors break a *rule* they will promptly take a penalty, which may be to retire.

WINDSURFING COMPETITION

Windsurfing competition shall be sailed under The Racing Rules of Sailing as changed by its Appendix B or, equivalently, under The Windsurfing Competition Rules. Wherever a rule of Appendix B appears in these windsurfing rules, its rule number is stated.

A windsurfing event can include one or more of the following disciplines or their formats:

Discipline	Formats
<i>Racing</i>	<i>Course racing; slalom; marathon</i>
<i>Expression</i>	<i>Wave performance; freestyle</i>
<i>Speed</i>	

In expression competition a board's performance is judged on skill and variety rather than speed and is organized using elimination series. Either wave performance or freestyle competition is organized, depending on the wave conditions at the venue. In speed competition, a 'round' consists of one or more speed runs in which the boards take turns sailing the course at intervals. In the racing discipline a marathon race is a race scheduled to last more than one hour.

In slalom racing or expression competition, 'heat' means one elimination contest, a 'round' consists of one or more heats, and an elimination series consists of a maximum of four rounds.

PART 1

FUNDAMENTAL RULES

1 SAFETY

1.1 Helping Those in Danger

A board or competitor shall give all possible help to any person or vessel in danger.

1.2 Life-Saving Equipment and Personal Buoyancy

A board shall carry adequate life-saving equipment according to her class rules. Each competitor is individually responsible for wearing personal buoyancy adequate for the conditions.

2 FAIR SAILING

A board and her owner shall compete in compliance with recognized principles of sportsmanship and fair play. A board may be penalized under this rule only if it is clearly established that these principles have been violated. A disqualification under this rule shall not be excluded from the board's series score.

3 ACCEPTANCE OF THE RULES

By participating in a race conducted under these racing rules, each competitor and board owner agrees

- (a) to be governed by the *rules*;
- (b) to accept the penalties imposed and other action taken under the *rules*, subject to the appeal and review procedures provided in them, as the final determination of any matter arising under the *rules*; and
- (c) where the matter is not one to be determined under the rules, not to resort to any court of law or any tribunal until all internal remedies provided by the ISAF or the Court of Arbitration for Sport have been exhausted.

4 DECISION TO RACE

The responsibility for a board's decision to participate in a race or to continue *racing* is hers alone.

5 BANNED SUBSTANCES AND METHODS

A competitor shall neither take a substance nor use a method banned by the Olympic Movement Anti-Doping Code or the World Anti-Doping Agency and shall comply with ISAF Regulation 21, Anti-Doping Code. An alleged or actual breach of this rule shall be dealt with under Regulation 21. It shall not be grounds for a *protest* and rule 63.1 does not apply.

PART 2

WHEN BOARDS MEET

The rules of Part 2 apply between boards that are sailing in or near the racing area and intend to **race**, are **racing**, or have been **racing**. However, a board not **racing** shall not be penalized for breaking one of these rules, except rule 22.1. When a board sailing under these rules meets a vessel that is not, she shall comply with the International Regulations for Preventing Collisions at Sea (IRPCAS) or government right-of-way rules. However, an alleged breach of those rules shall not be grounds for a **protest** except by the race committee or protest committee. If the sailing instructions so state, the rules of Part 2 are replaced by the right-of-way rules of the IRPCAS or by government right-of-way rules.

SECTION A

RIGHT OF WAY

A board has right of way when another board is required to **keep clear** of her. However, some rules in Sections B, C and D limit the actions of a right-of-way board.

10 ON OPPOSITE TACKS

When boards are on opposite *tacks*, a *port-tack* board shall *keep clear* of a *starboard-tack* board.

11 ON THE SAME TACK, OVERLAPPED

When boards are on the same *tack* and *overlapped*, a *windward* board shall *keep clear* of a *leeward* board.

12 ON THE SAME TACK, NOT OVERLAPPED

When boards are on the same *tack* and not *overlapped*, a board *clear astern* shall *keep clear* of a board *clear ahead*.

13 WHILE TACKING OR GYBING

13.1 After a board passes head to wind, she shall *keep clear* of other boards until she is on a close-hauled course. During that time rules

10, 11 and 12 do not apply. If two boards are subject to this rule at the same time, the one on the other's port side or the one astern shall *keep clear*.

13.2 A board gybing shall *keep clear* of other boards. During that time
B3.1 rules 10, 11 and 12 do not apply. If two boards are subject to this rule at the same time, the one on the other's port side or the one astern shall *keep clear*.

SECTION B

GENERAL LIMITATIONS

14 AVOIDING CONTACT

A board shall avoid contact with another board if reasonably possible. However, a right-of-way board or one entitled to *room*

- (a) need not act to avoid contact until it is clear that the other board is not *keeping clear* or giving *room*, and
- (b) shall not be penalized under this rule unless there is contact that causes damage or injury.

15 ACQUIRING RIGHT OF WAY

When a board acquires right of way, she shall initially give the other board *room to keep clear*, unless she acquires right of way because of the other board's actions.

16 CHANGING COURSE

16.1 When a right-of-way board changes course, she shall give the other board *room to keep clear*.

16.2 In addition, when after the starting signal a *port-tack* board is *keeping clear* by sailing to pass astern of a *starboard-tack* board, the *starboard-tack* board shall not change course if as a result the *port-tack* board would immediately need to change course to continue *keeping clear*.

17 Deleted.

B3.1

SECTION C

AT MARKS AND OBSTRUCTIONS

To the extent that a Section C rule conflicts with a rule in Section A or B, the Section C rule takes precedence.

18 ROUNDING AND PASSING MARKS AND OBSTRUCTIONS

*In rule 18, **room** is **room** for an inside board to round or pass between an outside board and a **mark** or **obstruction**, including **room** to tack or gybe when either is a normal part of the manoeuvre.*

18.1 When This Rule Applies

Rule 18 applies when boards are about to round or pass a *mark* they are required to leave on the same side, or an *obstruction* on the same side, until they have passed it. However, it does not apply

- (a) at a starting *mark* surrounded by navigable water or at its anchor line from the time the boards are approaching them to *start* until they have passed them, or
- (b) while the boards are on opposite *tacks*, either on a beat to windward or when the *proper course* for one of them, but not both, to round or pass the *mark* or *obstruction* is to tack.

18.2 Giving Room; Keeping Clear

(a) OVERLAPPED – BASIC RULE

When boards are *overlapped* the outside board shall give the inside board *room* to round or pass the *mark* or *obstruction*, and if the inside board has right of way the outside board shall also *keep clear*. Other parts of rule 18 contain exceptions to this rule.

(b) Deleted.

B3.1

(c) Deleted.

B3.1

(d) CHANGING COURSE TO ROUND OR PASS

When after the starting signal rule 18 applies between two boards and the right-of-way board is changing course to round or pass a *mark*, rule 16 does not apply between her and the other board.

(e) OVERLAP RIGHTS

If there is reasonable doubt that a board obtained or broke an *overlap* in time, it shall be presumed that she did not. If the outside board is unable to give *room* when an *overlap* begins, rules 18.2(a) and 18.2(b) do not apply.

18.3 Deleted.

B3.1

18.4 Gybing

When an inside *overlapped* right-of-way board must gybe at a *mark* or *obstruction* to sail her *proper course*, until she gybes she shall sail no farther from the *mark* or *obstruction* than needed to sail that course.

18.5 Passing a Continuing Obstruction

While boards are passing a continuing *obstruction*, rules 18.2(b) and 18.2(c) do not apply. A board *clear astern* that obtains an inside *overlap* is entitled to *room* to pass between the other board and the *obstruction* only if at the moment the *overlap* begins there is *room* to do so. If there is not, she is not entitled to *room* and shall *keep clear*.

19 ROOM TO TACK AT AN OBSTRUCTION

19.1 When approaching an *obstruction*, a board sailing close-hauled or above may hail for *room* to tack and avoid another board on the same *tack*. However, she shall not hail unless safety requires her to make a substantial course change to avoid the *obstruction*. Before tacking she shall give the hailed board time to respond. The hailed board shall respond by either

- (a) tacking as soon as possible, in which case the hailing board shall also tack as soon as possible, or
- (b) immediately replying ‘You tack’, in which case the hailing board shall tack as soon as possible and the hailed board shall give *room*, and rules 10 and 13 do not apply.

19.2 Rule 19.1 does not apply at a starting *mark* surrounded by navigable water or at its anchor line from the time boards are approaching them to *start* until they have passed them or at a *mark* that the hailed board can fetch. When rule 19.1 applies, rule 18 does not.

SECTION D OTHER RULES

When rule 20 or 21 applies between two boards, Section A rules do not.

20 STARTING ERRORS; PENALTY TURNS; MOVING ASTERN

20.1 A board sailing towards the pre-start side of the starting line or its extensions after her starting signal to *start* or to comply with rule 30.1 shall *keep clear* of a board not doing so until she is completely on the pre-start side.

20.2 A board making a penalty turn shall *keep clear* of one that is not.

20.3 A board moving astern by backing a sail shall *keep clear* of one that is not.

21 CAPSIZED, ANCHORED OR AGROUND; RESCUING

21.1 If possible, a board shall avoid a board that is capsized or has not regained control after capsizing, is anchored or aground, or is trying to help a person or vessel in danger. A board is capsized when her masthead is in the water.

21.2 A *capsized* board shall not take an action that hinders another board.

B3.1

22 INTERFERING WITH ANOTHER BOARD

22.1 If reasonably possible, a board not *racing* shall not interfere with a board that is *racing*.

22.2 A board shall not change course if her only purpose is to interfere with a board making a penalty turn or one on another leg or lap of the course.

22.3 A board shall not sail in the course area defined in the sailing instructions when races are taking place except in her own race.

B3.1

23 SAIL OUT OF THE WATER WHEN STARTING

B3.1 When approaching the starting line to *start*, a board shall have her sail out of the water and in a normal position, except when accidentally *capsized*.

SECTION E EXPRESSION AND SPEED COMPETITION

These rules replace all rules of Sections A, B, C and D.

24 RIGHT-OF-WAY RULES FOR EXPRESSION AND SPEED COMPETITION

24.1 Right-of-Way Rules for Expression Competition

B4.1 (a) COMING IN AND GOING OUT

A board *coming in* shall *keep clear* of a board *going out*. When two boards are *going out* or *coming in* while on the same wave, or when neither is *going out* or *coming in*, the board on *port tack* shall *keep clear* of the one on *starboard tack*.

(b) BOARDS ON THE SAME WAVE, COMING IN

When two or more boards are on a wave *coming in*, a board that does not have *possession* shall *keep clear*.

(c) CLEAR ASTERN, CLEAR AHEAD AND OVERTAKING

A board *clear astern* and not on a wave shall *keep clear* of a board *clear ahead*. An *overtaking* board that is not on a wave shall *keep clear*.

(d) TRANSITION

A board in *transition* shall *keep clear* of one that is not. When two boards are in *transition* at the same time, the one on the other's port side or the one astern shall *keep clear*.

24.2 Right-of-Way Rules for Speed Competition

B6.1 (a) BEACH AND WATER STARTING

A board shall not *beach start* or water start on the course or in the starting area, except to sail off the course to avoid boards that are *starting* or *racing*.

(b) LEAVING THE COURSE AREA

A board leaving the course area shall *keep clear* of boards *racing*.

PART 3 CONDUCT OF A RACE

25 NOTICE OF RACE, SAILING INSTRUCTIONS AND SIGNALS

The notice of race and sailing instructions shall be made available to each board before a race begins. The meanings of the visual and sound signals stated in Race Signals shall not be changed except under rule 86.1(b). The meanings of any other signals that may be used shall be stated in the sailing instructions.

26 STARTING SYSTEMS

26.1 Starting Races

B3.2 The sailing instructions shall specify one of these starting systems.

(a) SYSTEM 1

Races shall be started by using the following signals. Times shall be taken from the visual signals; the absence of a sound signal shall be disregarded.

<i>Signal</i>	<i>Flag and sound</i>	<i>Minutes before starting signal</i>
Warning	Class flag; 1 sound	5*
Preparatory	P, I, Z, Z with I, or black flag; 1 sound	4
One-minute	Preparatory flag removed; 1 long sound	1
Starting	Class flag removed; 1 sound	0

*or as stated in the sailing instructions

The warning signal for each succeeding class shall be made with or after the starting signal of the preceding class.

(b) SYSTEM 2

Races shall be started by using the following signals. Times shall be taken from the visual signals; the absence of a sound signal shall be disregarded.

<i>Signal</i>	<i>Flag and sound</i>	<i>Minutes before starting signal</i>
Attention	Class flag or heat number	5
	Attention signal removed	4
Warning	Red flag; 1 sound	3
	Red flag removed	2
Preparatory	Yellow flag; 1 sound	1
	Yellow flag removed	1/2
Starting	Green flag; 1 sound	0

(c) SYSTEM 3 (FOR BEACH STARTS)

- (1) Before her start each board in a heat or class shall draw a number for her station on the starting line. The stations shall be numbered so that station 1 is the most windward one.
- (2) After boards have been called to take their positions, the race committee shall make the preparatory signal by displaying a red flag with one sound. The starting signal shall be made, at any time after the preparatory signal, by removing the red flag with one sound.
- (3) After the starting signal each board shall take the shortest route from her starting station to her windsurfing position in the water (with both of the competitor's feet on the board).

26.2 Starting and Ending Heats for Expression Competition

B4.2 Heats shall be started and ended by using the following signals:

(a) STARTING A HEAT

Each flag shall be removed when the next flag is displayed.

<i>Signal</i>	<i>Flag and sound</i>	<i>Minutes before starting signal</i>
Attention	Heat number	3
Warning	Red flag; 1 sound	2
Preparatory	Yellow flag; 1 sound	1
Starting	Green flag; 1 sound	0

(b) ENDING A HEAT

<i>Signal</i>	<i>Flag and sound</i>	<i>Minutes before ending signal</i>
End warning	Green flag removed; 1 sound	1
Ending	Red flag; 1 sound	0

26.3 Starting System for Speed Competition

B6.2 Rounds shall be started and ended by using the following signals. Each flag shall be removed when the next flag is displayed.

(a) STARTING A ROUND

<i>Signal</i>	<i>Flag</i>	<i>Meaning</i>
Stand-by	Red flag	Course closed
Course closed	AP and red flag	Course closed; will open shortly
Preparatory	Yellow flag	Course will open in 5 minutes
Starting	Green flag	Course is open

(b) ENDING A ROUND

<i>Signal</i>	<i>Flag</i>	<i>Meaning</i>
End warning	Green and yellow flag	Course will be closed in 5 minutes
Extension	Green flag and L	Current round extended by 15 minutes
Round ended	Red flag and L	A new round will be started shortly

27 OTHER RACE COMMITTEE ACTIONS BEFORE THE STARTING SIGNAL

27.1 No later than the warning signal, the race committee shall signal or otherwise designate the course to be sailed if the sailing instructions have not stated the course, and it may replace one course signal

with another and signal that wearing personal buoyancy is required (display flag Y with one sound).

27.2 No later than the preparatory signal, the race committee may move a starting *mark* and may apply rule 30.

27.3 Before the starting signal, the race committee may for any reason *postpone* (display flag AP, AP over H, or AP over A, with two sounds) or *abandon* the race (display flag N over H, or N over A, with three sounds).

28 SAILING THE COURSE

28.1 A board shall *start*, leave each *mark* on the required side in the correct order, and *finish*, so that a string representing her wake after *starting* and until *finishing* would when drawn taut pass each *mark* on the required side and touch each rounding *mark*. She may correct any errors to comply with this rule. After *finishing* she need not cross the finishing line completely.

28.2 A board may leave on either side a *mark* that does not begin, bound or end the leg she is on. However, she shall leave a starting *mark* on the required side when she is approaching the starting line from its pre-start side to *start*.

29 RECALLS**29.1 Individual Recall**

When at a board's starting signal any part of her hull, crew or equipment is on the course side of the starting line or she must comply with rule 30.1, the race committee shall promptly display flag X with one sound. The flag shall be displayed until all such boards are completely on the pre-start side of the starting line or its extensions and have complied with rule 30.1 if it applies, but not later than four minutes after the starting signal or one minute before any later starting signal, whichever is earlier.

29.2 General Recall

When at the starting signal the race committee is unable to identify boards that are on the course side of the starting line or to which rule 30 applies, or there has been an error in the starting procedure, the race committee may signal a general recall (display the First Substitute with two sounds). The warning signal for a new start for

the recalled class shall be made one minute after the First Substitute is removed (one sound), and the starts for any succeeding classes shall follow the new start.

29.3 Recall for a Slalom Race

- B3.3** (a) When at a board's starting signal for a slalom race or heat any part of her hull, crew or equipment is on the course side of the starting line, the race committee shall signal a general recall.
- (b) If the race committee acts under rule 29.3(a) and the board is identified, she shall be disqualified without a hearing, even if the race or heat is *postponed* or *abandoned*. The race committee shall hail or display her sail number, and she shall leave the course area immediately. If the race or heat is restarted or resailed, she shall not sail in it.

30 STARTING PENALTIES

30.1 Round-an-End Rule

If flag I has been displayed, and any part of a board's hull, crew or equipment is on the course side of the starting line or its extensions during the minute before her starting signal, she shall thereafter sail from the course side across an extension to the pre-start side before *starting*.

30.2 20% Penalty Rule

If flag Z has been displayed, no part of a board's hull, crew or equipment shall be in the triangle formed by the ends of the starting line and the first *mark* during the minute before her starting signal. If a board breaks this rule and is identified, she shall receive, without a hearing, a 20% scoring penalty calculated as stated in rule 44.3(c). She shall be penalized even if the race is restarted, resailed or rescheduled, but not if it is *postponed* or *abandoned* before the starting signal.

30.3 Black Flag Rule

If a black flag has been displayed, no part of a board's hull, crew or equipment shall be in the triangle formed by the ends of the starting line and the first *mark* during the minute before her starting signal. If a board breaks this rule and is identified, she shall be disqualified without a hearing, even if the race is restarted, resailed or rescheduled, but not if it is *postponed* or *abandoned* before the starting

signal. If a general recall is signalled or the race is *abandoned* after the starting signal, the race committee shall display her sail number before the next warning signal for that race, and if the race is restarted or resailed she shall not sail in it. If she does so, her disqualification shall not be excluded in calculating her series score. If this rule applies rule 29.1 does not.

31 TOUCHING A MARK

- B3.3** A board may touch a *mark* but shall not hold on to it.

32 SHORTENING OR ABANDONING AFTER THE START

- 32.1** After the starting signal, the race committee may shorten the course (display flag S with two sounds) or *abandon* the race (display flag N, N over H, or N over A, with three sounds), as appropriate,

- (a) because of an error in the starting procedure,
- (b) because of foul weather,
- (c) because of insufficient wind making it unlikely that any board will *finish* within the time limit,
- (d) because a *mark* is missing or out of position, or
- (e) for any other reason directly affecting the safety or fairness of the competition,

or may shorten the course so that other scheduled races can be sailed. However, after one board has sailed the course and *finished* within the time limit, if any, the race committee shall not *abandon* the race without considering the consequences for all boards in the race or series.

- 32.2** If the race committee signals a shortened course (displays flag S with two sounds), the finishing line shall be,

- (a) at a rounding *mark*, between the *mark* and a staff displaying flag S;
- (b) at a line boards are required to cross at the end of each lap, that line;
- (c) at a gate, between the gate *marks*.

33 CHANGING THE NEXT LEG OF THE COURSE

The race committee may change a leg of the course that begins at a rounding *mark* by changing the position of the next *mark* (or the finishing line) and signalling all boards before they begin the leg. The next *mark* need not be in position at that time.

- (a) If the direction of the leg will be changed, the signal shall be the display of flag C with repetitive sounds and either
 - (1) the new compass bearing or
 - (2) a green triangular flag or board for a change to starboard or a red rectangular flag or board for a change to port.
- (b) If the length of the leg will be changed, the signal shall be the display of flag C with repetitive sounds and a ‘-’ if the leg will be shortened or a ‘+’ if the leg will be lengthened.
- (c) Subsequent legs may be changed without further signalling to maintain the course shape.

34 MARK MISSING

If a *mark* is missing or out of position, the race committee shall, if possible,

- (a) replace it in its correct position or substitute a new one of similar appearance, or
- (b) substitute an object displaying flag M and make repetitive sound signals.

35 TIME LIMIT AND SCORES

If one board sails the course as required by rule 28.1 and *finishes* within the time limit, if any, all boards that *finish* shall be scored according to their finishing places unless the race is *abandoned*. If no board *finishes* within the time limit, the race committee shall *abandon* the race.

36 RACES RESTARTED OR RESAILED

If a race is restarted or resailed, a breach of a *rule*, other than rule 30.3, in the original race shall not prohibit a board from competing or, except under rule 30.2, 30.3 or 69, cause her to be penalized.

37 EXPRESSION COMPETITION – REGISTRATION OF SAILS; COURSE AREA; HEAT DURATION

37.1 Boards shall register with the race committee the colours and other particulars of their sails, or their identification according to another method stated in the sailing instructions, no later than the starting signal for the heat two heats before their own.

37.2 The course area shall be defined in the sailing instructions and posted on the official notice board not later than 30 minutes before the starting signal for the first heat. A board shall be scored only while sailing in the course area.

37.3 Any change in heat duration shall be announced by the race committee not later than fifteen minutes before the starting signal for the first heat in the next round.

38 ELIMINATION SERIES FOR SLALOM RACING AND EXPRESSION COMPETITION

Rules 38.1–38.5 apply to slalom racing or expression competition organized by using elimination series in which boards compete in heats.

38.1 Elimination Series Procedure

- B5.1** (a) Competition shall take the form of one or more elimination series. Each of them shall consist of either a maximum of four rounds in a single elimination series where only a number of the best scorers advance, or a maximum of ten rounds in a double elimination series where boards have more than one opportunity to advance.
- (b) Boards shall sail one against another in pairs, or in groups determined by the elimination ladder. The selected form of competition shall not be changed while a round remains uncompleted.

38.2 Seeding and Ranking Lists

- B5.2** (a) When a seeding or ranking list is used to establish the heats of the first round, places 1–8 (four heats) or 1–16 (eight heats) shall be distributed evenly among the heats.

- (b) For a subsequent elimination series, if any, boards shall be reassigned to new heats according to a seeding list based on the current overall standings.
- (c) The organizing authority's seeding decisions are final and are not grounds for a request for redress.

38.3 Heat Schedule

B5.3 The schedule of heats shall be posted on the official notice board not later than 30 minutes before the starting signal for the first heat.

38.4 Advancement and Byes

- B5.4**
- (a) In slalom racing and freestyle competition, the boards in each heat to advance to the next round shall be announced by the race committee not later than 30 minutes before the starting signal for the first heat. The number advancing may be changed by the protest committee as a result of a redress decision.
 - (b) In expression competition, any first-round byes shall be assigned to the highest-seeded boards.
 - (c) In wave performance competition, only the winner of each heat shall advance to the next round.
 - (d) In freestyle competition, boards shall advance to the next round as follows: from an eight-board heat, the best four advance, and the winner will sail against the fourth and the second against the third; from a four-board heat, the best two advance and will sail against each other.

38.5 Finals

- B5.5**
- (a) The final shall consist of a maximum of three races. The race committee shall announce the number of races to be sailed in the final not later than five minutes before the warning signal for the first final race.
 - (b) A runners-up final may be sailed after the final. All boards in the semifinal heats that failed to qualify for the final may compete in it.

39 SPECIAL RULES FOR SPEED COMPETITION

39.1 General Rules

- B6.1**
- (a) COURSE CONTROL
When the race committee points an orange flag at a board, she shall immediately leave the course area.
 - (b) RETURNING TO THE STARTING AREA
A board returning to the starting area shall keep clear of the course.
 - (c) RUN; ROUND
The maximum number of runs to be made by each board in a round shall be announced by the race committee not later than 30 minutes before the starting signal for the first round.
 - (d) DURATION OF A ROUND
The duration of a round shall be announced by the race committee not later than 30 minutes before the starting signal for the next round.
 - (e) CONDITIONS FOR ESTABLISHING A RECORD
The minimum distance for a world record is 500 metres. Other records may be established over shorter distances. The course shall be defined by posts and transits ashore or by buoys afloat. Transits shall not converge.

39.2 Penalties

- B6.3**
- (a) If a board fails to comply with a warning by the race committee, she may be cautioned and her sail number shall be posted on a notice board near the finishing line.
 - (b) If a board is cautioned a second time during the same round, she shall be suspended by the race committee from the remainder of the round and her sail number shall be posted on the official notice board.
 - (c) A board observed in the course area while suspended shall be disqualified from the competition without a hearing and none of her previous times or results shall be valid.
 - (d) Any breach of the verification rules may result in a suspension from the competition for any period.

39.3 Verification

- B6.4** (a) An observer appointed by the World Sailing Speed Record Council (WSSRC) shall be present and verify run times and speeds at world record attempts. The race committee shall verify run times and speeds at other record attempts.
- (b) A competitor shall not enter the timing control area or discuss any timing matter directly with the timing organization. Any timing question shall be directed to the race committee.

PART 4

OTHER REQUIREMENTS WHEN RACING

Part 4 rules apply only to boards racing.

40 PERSONAL BUOYANCY; HARNESES

40.1 When flag Y is displayed with one sound before or with the warning signal, competitors shall wear life-jackets or other adequate personal buoyancy. Wet suits and dry suits are not adequate personal buoyancy.

40.2 Not applicable to windsurfing.

41 OUTSIDE HELP

41.1 A board shall not receive help from any outside source, except

- (a) help as provided for in rule 1;
- (b) help for an ill or injured competitor;
- (c) after a collision, help from the crew of the other board to get clear;
- (d) help in the form of information freely available to all boards;
- (e) unsolicited information from a disinterested source, which may be another board in the same race.

41.2 Outside Help for Expression Competition

B4.4 An assistant may provide replacement equipment to a board but shall keep clear of other boards competing. A board whose assistant fails to keep clear shall be penalized. The penalty shall be at the discretion of the protest committee.

42 PROPULSION

B2.1 A board shall be propelled only by the action of the wind on the sail, by the action of the water on the hull and by the unassisted actions of the competitor.

43 COMPETITOR CLOTHING AND EQUIPMENT

- 43.1** (a) Competitors shall not wear or carry clothing or equipment for the purpose of increasing their weight. However, a competitor may wear a drinking container that shall have a capacity of at least one litre and weigh no more than 1.5 kilograms when full.
- B2.1**
- (b) Furthermore, a competitor's clothing and equipment shall not weigh more than 8 kilograms, excluding a hiking or trapeze harness and clothing (including footwear) worn only below the knee. Class rules or sailing instructions may specify a lower weight or a higher weight up to 10 kilograms. Class rules may include footwear and other clothing worn below the knee within that weight. A hiking or trapeze harness shall have positive buoyancy and shall not weigh more than 2 kilograms, except that class rules may specify a higher weight up to 4 kilograms. Weights shall be determined as required by Appendix H.
- (c) When a measurer in charge of weighing clothing and equipment believes a competitor may have broken rule 43.1(a) or 43.1(b) he shall report the matter in writing to the race committee, which shall protest the board of the competitor.

43.2 Not applicable to windsurfing.

44 PENALTIES FOR BREAKING RULES OF PART 2**44.1 Taking a Penalty**

B2.1 A board that may have broken a rule of Part 2 while *racing* may take a penalty at the time of the incident. Her penalty shall be a Turn Penalty unless the sailing instructions specify the use of some other penalty. However, if she caused injury or serious damage or gained a significant advantage in the race or series by her breach her penalty shall be to retire.

44.2 Turn Penalty

B2.1 After getting well clear of other boards as soon after the incident as possible, a board takes a Turn Penalty by promptly making one 360° turn. When a board takes the penalty at or near the finishing line, she shall sail completely to the course side of the line before *finishing*.

44.3 Scoring Penalty

(a) Deleted.

B2.1

(b) Deleted.

B2.1

(c) The board's penalty score shall be the score for the place worse than her actual finishing place by the number of places stated in the sailing instructions, except that she shall not be scored worse than Did Not Finish. When the sailing instructions do not state the number of places, the number shall be the whole number (rounding 0.5 upward) nearest to 20% of the number of boards entered. The scores of other boards shall not be changed; therefore, two boards may receive the same score.

44.4 Limits on Penalties

(a) Deleted.

B2.1

(b) A board that takes a penalty shall not be penalized further with respect to the same incident unless she failed to retire when rule 44.1 required her to do so.

45 HAULING OUT; MAKING FAST; ANCHORING

A board shall be afloat and off moorings at her preparatory signal. Thereafter, she shall not be hauled out or made fast except to bail out, reef sails or make repairs. She may anchor or the crew may stand on the bottom. She shall recover the anchor before continuing in the race unless she is unable to do so.

46 PERSON IN CHARGE

A board shall have on board a person in charge designated by the member or organization that entered the board. See rule 75.

47 LIMITATIONS ON EQUIPMENT AND CREW

47.1 A board shall use only the equipment on board at her preparatory signal except as stated in rule 41.2.

B2.1

47.2 Deleted.

B2.1

48 FOG SIGNALS AND LIGHTS

When safety requires, a board shall sound fog signals and show lights as required by the *International Regulations for Preventing Collisions at Sea* or applicable government rules.

49 Not applicable to windsurfing.

50 Not applicable to windsurfing.

51 Not applicable to windsurfing.

52 Not applicable to windsurfing.

53 SKIN FRICTION

A board shall not eject or release a substance, such as a polymer, or have specially textured surfaces that could improve the character of the flow of water inside the boundary layer.

54 Not applicable to windsurfing.

PART 5

**PROTESTS, REDRESS, HEARINGS,
MISCONDUCT AND APPEALS**

SECTION A

PROTESTS; REDRESS; RULE 69 ACTION

**60 RIGHT TO PROTEST; RIGHT TO REQUEST REDRESS OR
RULE 69 ACTION**

60.1 A board may

- (a) protest another board, but not for an alleged breach of a rule of Part 2 unless she was involved in or saw the incident; or
- (b) request redress.

60.2 A race committee may

- (a) protest a board, but not as a result of a report from an *interested party* or information in an invalid *protest* or in a request for redress;
- (b) request redress for a board; or
- (c) report to the protest committee requesting action under rule 69.1(a).

60.3 A protest committee may

- (a) protest a board, but not as a result of a report from an *interested party* or information in an invalid *protest* or in a request for redress. However, it may protest a board
 - (1) if it learns of an incident involving her that may have resulted in injury or serious damage, or
 - (2) if during the hearing of a valid *protest* it learns that the board, although not a *party* to the hearing, was involved in the incident and may have broken a *rule*;
- (b) call a hearing to consider redress; or
- (c) act under rule 69.1(a).

61 PROTEST REQUIREMENTS**61.1 Informing the Protestee**

- B7.1** (a) A board intending to protest shall inform the other board at the first reasonable opportunity. When her *protest* concerns an incident in the racing area that she is involved in or sees, she shall hail 'Protest'. She shall inform the race committee of her intention to protest immediately after she *finishes* or retires. However,
- (1) if the other board is beyond hailing distance, the protesting board need not hail but she shall inform the other board at the first reasonable opportunity;
 - (2) Not applicable to windsurfing.
 - (3) if the incident results in damage or injury that is obvious to the boards involved and one of them intends to protest, the requirements of this rule do not apply to her, but she shall attempt to inform the other board within the time limit of rule 61.3.
- (b) A race committee or protest committee intending to protest a board shall inform her as soon as reasonably possible. However, if the *protest* arises from an incident the committee observes in the racing area, it shall inform the board after the race within the time limit of rule 61.3.
- (c) If the protest committee decides to protest a board under rule 60.3(a)(2), it shall inform her as soon as reasonably possible, close the current hearing, proceed as required by rules 61.2 and 63, and hear the original and the new *protests* together.

61.2 Protest Contents**B7.1** (a) COURSE AND MARATHON RACING

A *protest* shall be in writing and identify

- (a) the protestor and protestee;
- (b) the incident, including where and when it occurred;
- (c) any *rule* the protestor believes was broken; and
- (d) the name of the protestor's representative.

However, if requirement (b) is met, requirement (a) may be met at any time before the hearing, and requirements (c) and (d) may be met before or during the hearing.

(b) SLALOM RACING AND OTHER DISCIPLINES

A *protest* shall be made orally immediately following the heat in which the incident occurred.

61.3 Protest Time Limit

A *protest* by a board, or by the race committee or protest committee about an incident the committee observes in the racing area, shall be delivered to the race office no later than the time limit stated in the sailing instructions. If none is stated, the time limit is two hours after the last board in the race *finishes*. Other race committee or protest committee *protests* shall be delivered to the race office within two hours after the committee receives the relevant information. The protest committee shall extend the time if there is good reason to do so.

62 REDRESS**62.1** A request for redress or a protest committee's decision to consider redress shall be based on a claim or possibility that a board's score in a race or series has, through no fault of her own, been made significantly worse by

- (a) an improper action or omission of the race committee, protest committee or organizing authority;
- (b) injury or physical damage because of the action of a board that was breaking a rule of Part 2 or of a vessel not *racing* that was required to keep clear;
- (c) giving help (except to herself or her crew) in compliance with rule 1.1;
- (d) a board against which a penalty has been imposed under rule 2 or disciplinary action has been taken under rule 69.1(b); or
- (e) a board that failed to *keep clear* and retired or was penalized.

B7.2**62.2** The request shall be made in writing, except in an elimination series, **B7.3** within the time limit of rule 61.3 or within two hours of the relevant incident, whichever is later. The protest committee shall extend the time if there is good reason to do so. No red flag is required.

SECTION B**HEARINGS AND DECISIONS****63 HEARINGS****63.1 Requirement for a Hearing**

A board or competitor shall not be penalized without a protest hearing, except as provided in rules 30.2, 30.3, 67, 69, A5 and P2. A decision on redress shall not be made without a hearing. The protest committee shall hear all *protests* and requests for redress that have been delivered to the race office unless it allows a *protest* or request to be withdrawn.

63.2 Time and Place of the Hearing; Time for Parties to Prepare

- B7.4** (a) All *parties* to the hearing shall be notified of the time and place of the hearing, the *protest* or redress information shall be made available to them, and they shall be allowed reasonable time to prepare for the hearing.
- (b) In an elimination series, the protest committee may hear a *protest* on the beach or water immediately after the heat.

63.3 Right to Be Present

- (a) The *parties* to the hearing, or a representative of each, have the right to be present throughout the hearing of all the evidence. When a *protest* claims a breach of a rule of Part 2, 3 or 4, the representatives of boards shall have been on board at the time of the incident, unless there is good reason for the protest committee to rule otherwise. Any witness, other than a member of the protest committee, shall be excluded except when giving evidence.
- (b) If a *party* to the hearing does not come to the hearing, the protest committee may nevertheless decide the *protest* or request for redress. If the *party* was unavoidably absent, the committee may reopen the hearing.

63.4 Interested Party

A member of a protest committee who is an *interested party* shall not take any further part in the hearing but may appear as a witness. A *party* to the hearing who believes a member of the protest committee is an *interested party* shall object as soon as possible.

63.5 Validity of the Protest or Request for Redress

At the beginning of the hearing the protest committee shall decide whether all requirements for the *protest* or request for redress have been met, after first taking any evidence it considers necessary. If all requirements have been met, the *protest* or request is valid and the hearing shall be continued. If not, it shall be closed. If the *protest* has been made under rule 60.3(a)(1), the protest committee shall also determine whether or not injury or serious damage resulted from the incident in question. If not, the hearing shall be closed.

63.6 Taking Evidence and Finding Facts

The protest committee shall take the evidence of the *parties* to the hearing and of their witnesses and other evidence it considers necessary. A member of the protest committee who saw the incident may give evidence. A *party* to the hearing may question any person who gives evidence. The committee shall then find the facts and base its decision on them.

63.7 Conflict between Rules

If there is a conflict between a *rule* in the notice of race and one in the sailing instructions that must be resolved before the protest committee can decide a *protest* or request for redress, the committee shall apply the *rule* that it believes will provide the fairest result for all boards affected.

63.8 Protests between Boards in Different Races

A *protest* between boards sailing in different races conducted by different organizing authorities shall be heard by a protest committee acceptable to those authorities.

64 DECISIONS**64.1 Penalties and Exoneration**

- (a) When the protest committee decides that a board that is a *party* to a protest hearing has broken a *rule*, it shall disqualify her unless some other penalty applies. A penalty shall be imposed whether or not the applicable *rule* was mentioned in the *protest*.

- (b) When as a consequence of breaking a *rule* a board has compelled another board to break a *rule*, rule 64.1(a) does not apply to the other board and she shall be exonerated.
- (c) If a board has broken a *rule* when not *racing*, her penalty shall apply to the race sailed nearest in time to that of the incident.

64.2 Decisions on Redress

When the protest committee decides that a board is entitled to redress under rule 62, it shall make as fair an arrangement as possible for all boards affected, whether or not they asked for redress. This may be to adjust the scoring (see rule A10 for some examples) or finishing times of boards, to *abandon* the race, to let the results stand or to make some other arrangement. When in doubt about the facts or probable results of any arrangement for the race or series, especially before *abandoning* the race, the protest committee shall take evidence from appropriate sources.

64.3 Decisions on Measurement Protests

- (a) When the protest committee finds that deviations in excess of tolerances specified in the class rules were caused by damage or normal wear and do not improve the performance of the board, it shall not penalize her. However, the board shall not *race* again until the deviations have been corrected, except when the protest committee decides there is or has been no reasonable opportunity to do so.
- (b) When the protest committee is in doubt about the meaning of a measurement rule, it shall refer its questions, together with the relevant facts, to an authority responsible for interpreting the rule. In making its decision, the committee shall be bound by the reply of the authority.
- (c) When a board disqualified under a measurement rule states in writing that she intends to appeal, she may compete in subsequent races without changes to the board, but shall be disqualified if she fails to appeal or the appeal is decided against her.
- (d) Measurement costs arising from a *protest* involving a measurement rule shall be paid by the unsuccessful *party* unless the protest committee decides otherwise.

65 INFORMING THE PARTIES AND OTHERS

65.1 After making its decision, the protest committee shall promptly inform the *parties* to the hearing of the facts found, the applicable *rules*, the decision, the reasons for it, and any penalties imposed or redress given.

65.2 Except in an elimination series, a *party* to the hearing is entitled to receive the above information in writing, provided she asks for it in writing from the protest committee within seven days of being informed of the decision. The committee shall then promptly provide the information, including, when relevant, a diagram of the incident prepared or endorsed by the committee.

65.3 When the protest committee penalizes a board under a measurement rule, it shall send the above information to the relevant measurement authorities.

66 REOPENING A HEARING

The protest committee may reopen a hearing when it decides that it may have made a significant error, or when significant new evidence becomes available within a reasonable time. It shall reopen a hearing when required by the national authority under rule F5. A *party* to the hearing may ask for a reopening no later than 24 hours after being informed of the decision. When a hearing is reopened, a majority of the members of the protest committee shall, if possible, be members of the original protest committee.

67 Deleted.

B7.6

68 DAMAGES

The question of damages arising from a breach of any *rule* shall be governed by the prescriptions, if any, of the national authority.

SECTION C**GROSS MISCONDUCT****69 ALLEGATIONS OF GROSS MISCONDUCT****69.1 Action by a Protest Committee**

- (a) When a protest committee, from its own observation or a report received from any source, believes that a competitor may have committed a gross breach of a *rule*, good manners or sportsmanship, or may have brought the sport into disrepute, it may call a hearing. The protest committee shall promptly inform the competitor in writing of the alleged misconduct and of the time and place of the hearing.
- (b) A protest committee of at least three members shall conduct the hearing, following rules 63.2, 63.3, 63.4 and 63.6. If it decides that the competitor committed the alleged misconduct it shall either
 - (1) warn the competitor or
 - (2) impose a penalty by excluding the competitor and, when appropriate, disqualifying a board, from a race or the remaining races or all races of the series, or by taking other action within its jurisdiction. A disqualification under this rule shall not be excluded from the board's series score.
- (c) The protest committee shall promptly report a penalty, but not a warning, to the national authorities of the venue, of the competitor and of the board owner.
- (d) If there is good reason for the competitor not to attend the hearing, the protest committee shall postpone it. However, if the competitor has left the event and as a result cannot reasonably be expected to attend a hearing, the protest committee shall not conduct one. Instead, it shall collect all available information and, if the allegation seems justified, make a report to the relevant national authorities.
- (e) When the protest committee has left the event and a report alleging misconduct is received, the race committee or organizing authority may appoint a new protest committee to proceed under this rule.

69.2 Action by a National Authority

- (a) When a national authority receives a report required by rule 69.1(c) or 69.1(d), a report alleging a gross breach of a *rule*, good manners or sportsmanship, or a report alleging conduct that has brought the sport into disrepute, it may conduct an investigation and, when appropriate, shall conduct a hearing. It may then take any disciplinary action within its jurisdiction it considers appropriate against the competitor or board, or other person involved, including suspending eligibility, permanently or for a specified period of time, to compete in any event held within its jurisdiction, and suspending ISAF eligibility under ISAF Regulation 19.
- (b) The national authority of a competitor shall also suspend the ISAF eligibility of the competitor as required in ISAF Regulation 19.
- (c) The national authority shall promptly report a suspension of eligibility under rule 69.2(a) to the ISAF, and to the national authorities of the person or the owner of the board suspended if they are not members of the suspending national authority.

69.3 Action by the ISAF

Upon receipt of a report required by rule 69.2(c) or ISAF Regulation 19, the ISAF shall inform all national authorities, which may also suspend eligibility for events held within their jurisdiction. The ISAF Executive Committee shall suspend the competitor's ISAF eligibility as required in ISAF Regulation 19 if the competitor's national authority does not do so.

**SECTION D
APPEALS****70 APPEALS; CONFIRMATION OR CORRECTION OF DECISIONS; RULE INTERPRETATIONS**

- 70.1** Provided that the right of appeal has not been denied under rule 70.4, a *party* to a hearing may appeal a protest committee's decision or its procedures, but not the facts found, to the national authority of the venue.

- 70.2** A protest committee may request confirmation or correction of its decision.
- 70.3** A club or other organization affiliated to a national authority may request an interpretation of the *rules*, provided that no *protest* or request for redress that may be appealed is involved. The interpretation shall not be used for changing a previous protest committee decision.
- 70.4** There shall be no appeal from the decisions of an international jury constituted in compliance with Appendix N. Furthermore, if the notice of race and the sailing instructions so state, the right of appeal may be denied provided that
- (a) it is essential to determine promptly the result of a race that will qualify a board to compete in a later stage of an event or a subsequent event (a national authority may prescribe that its approval is required for such a procedure);
 - (b) a national authority so approves for a particular event open only to entrants under its own jurisdiction; or
 - (c) a national authority after consultation with the ISAF so approves for a particular event, provided the protest committee is constituted as required by Appendix N, except that only two members of the protest committee need be International Judges.
- 70.5** Appeals and requests shall conform to Appendix F.
- 70.6** Appeals are not permitted in slalom racing and expression competition.
- B7.7**

71 APPEAL DECISIONS

- 71.1** No *interested party* or member of the protest committee shall take any part in the discussion or decision on an appeal or a request for confirmation or correction.
- 71.2** The national authority may uphold, change or reverse the protest committee's decision; declare the *protest* or request for redress invalid; or return the *protest* or request for the hearing to be reopened, or for a new hearing and decision by the same or a different protest committee.

- 71.3** When from the facts found by the protest committee the national authority decides that a board that was a *party* to a protest hearing broke a *rule*, it shall penalize her, whether or not that board or that *rule* was mentioned in the protest committee's decision.
- 71.4** The decision of the national authority shall be final. The national authority shall send its decision in writing to all *parties* to the hearing and the protest committee, who shall be bound by the decision.

PART 6**ENTRY AND QUALIFICATION****75 ENTERING A RACE**

75.1 To enter a race, a board shall comply with the requirements of the organizing authority of the race. She shall be entered by

- (a) a member of a club or other organization affiliated to an ISAF member national authority,
- (b) such a club or organization, or
- (c) a member of an ISAF member national authority.

75.2 Competitors shall comply with ISAF Regulation 19, Eligibility Code.

76 EXCLUSION OF BOARDS OR COMPETITORS

76.1 The organizing authority or the race committee may reject or cancel the entry of a board or exclude a competitor, subject to rule 76.2, provided it does so before the start of the first race and states the reason for doing so. However, the organizing authority or the race committee shall not reject or cancel the entry of a board or exclude a competitor because of advertising, provided the board or competitor complies with ISAF Regulation 20, Advertising Code.

76.2 At world and continental championships no entry within stated quotas shall be rejected or cancelled without first obtaining the approval of the relevant international class association or the ISAF.

77 IDENTIFICATION ON SAILS

A board shall comply with the requirements of Appendix G governing class insignia, national letters and numbers on sails.

78 COMPLIANCE WITH CLASS RULES; CERTIFICATES

78.1 A board's owner and any other person in charge shall ensure that the board is maintained to comply with her class rules and that her measurement or rating certificate, if any, remains valid. When so prescribed by the ISAF, a numbered and dated device on a board and her centreboard, fin and rig shall serve as her measurement certificate.

78.2 When a *rule* requires a certificate to be produced before a board *aces*, and it is not produced, the board may *race* provided that the race committee receives a statement signed by the person in charge that a valid certificate exists and that it will be given to the race committee before the end of the event. If the certificate is not received in time, the board shall be disqualified from all races of the event.

78.3 When a measurer for an event decides that a board or personal equipment does not comply with the class rules, he shall report the matter in writing to the race committee, which shall protest the board.

79 ADVERTISING

A board and her crew shall comply with ISAF Regulation 20, Advertising Code.

80 RESCHEDULED RACES

When a race has been rescheduled, rule 36 applies and all boards entered in the original race shall be notified and, unless disqualified under rule 30.3, be entitled to sail the rescheduled race. New entries that meet the entry requirements of the original race may be accepted at the discretion of the race committee.

PART 7**RACE ORGANIZATION****85 GOVERNING RULES**

The organizing authority, race committee and protest committee shall be governed by the *rules* in the conduct and judging of races.

86 CHANGES TO THE RACING RULES

86.1 A racing rule shall not be changed unless permitted in the rule itself or as follows:

- (a) Prescriptions of a national authority may change a racing rule, but not the Definitions; a rule in the Introduction; Sportsmanship and the Rules; Part 1, 2 or 7; rule 42, 43.1, 43.2, 69, 70, 71, 75, 76.2 or 79; a rule of an appendix that changes one of these rules; Appendix H or N; or ISAF Regulation 19, 20 or 21.
- (b) Sailing instructions may change a racing rule by referring specifically to it and stating the change, but not rule 76.1, Appendix F, or a rule listed in rule 86.1(a).
- (c) Class rules may change only racing rules 42, 49, 50, 51, 52, 53 and 54.

86.2 In exception to rule 86.1, the ISAF may in limited circumstances (see ISAF Regulation 31.1.3) authorize changes to the racing rules for a specific international event. The authorization shall be stated in a letter of approval to the event organizing authority and in the notice of race and sailing instructions, and the letter shall be posted on the event's official notice board.

86.3 If a national authority so prescribes, these restrictions do not apply if rules are changed to develop or test proposed rules. The national authority may prescribe that its approval is required for such changes.

87 CHANGES TO NATIONAL AUTHORITY PRESCRIPTIONS

A national authority may restrict changes to its prescriptions with a prescription to this rule. If it does so, that prescription shall not be changed or deleted by sailing instructions.

88 ORGANIZING AUTHORITY; NOTICE OF RACE; APPOINTMENT OF RACE OFFICIALS**88.1 Organizing Authority**

Races shall be organized by an organizing authority, which shall be

- (a) the ISAF;
- (b) a member national authority of the ISAF;
- (c) a club or other organization affiliated to a national authority;
- (d) a class association, either with the approval of a national authority or in conjunction with an affiliated club;
- (e) an unaffiliated body in conjunction with an affiliated club where the body is owned and controlled by the club. The national authority of the club may prescribe that its approval is required for such an event; or
- (f) if approved by the ISAF and the national authority of the club, an unaffiliated body in conjunction with an affiliated club where the body is not owned and controlled by the club.

88.2 Notice of Race; Appointment of Race Officials

- (a) The organizing authority shall publish a notice of race that conforms to rule J1. The notice of race may be changed provided adequate notice is given.
- (b) The organizing authority shall appoint a race committee and, when appropriate, appoint a protest committee and umpires. However, the race committee, an international jury and umpires may be appointed by the ISAF as provided in the ISAF regulations.

89 RACE COMMITTEE; SAILING INSTRUCTIONS; SCORING**89.1 Race Committee**

The race committee shall conduct races as directed by the organizing authority and as required by the *rules*.

89.2 Sailing Instructions

- (a) The race committee shall publish written sailing instructions that conform to rule J2.

- (b) The sailing instructions for an international event shall include, in English, the applicable prescriptions of the national authority.
- (c) Changes to the sailing instructions shall be in writing and **B2.3** posted within the required time on the official notice board or, on the water, communicated to each board before her warning signal.
- (d) Oral instructions may be given only if the procedure is stated in **B2.3** the sailing instructions.

89.3 Scoring

- B8.3** (a) The race committee shall score a race or series as provided in Appendix A using the Low Point System, unless the sailing instructions specify the Alternative System or some other system. A race shall be scored if it is not *abandoned* and if one board sails the course in compliance with rule 28.1 and *finishes* within the time limit, if any, even if she retires after *finishing* or is disqualified.
- (b) When a scoring system provides for excluding one or more race scores from a board's series score, the score for disqualification under rule 2; rule 30.3's next-to-last sentence; rule 42 if rule 67, P2.2 or P2.3 applies; or rule 69.1(b)(2) shall not be excluded. The next-worse score shall be excluded instead.

90 PROTEST COMMITTEE

A protest committee shall be

- (a) a committee appointed by the organizing authority or race committee, or
- (b) an international jury appointed by the organizing authority or as prescribed in the ISAF regulations and meeting the requirements of Appendix N. A national authority may prescribe that its approval is required for the appointment of international juries for races within its jurisdiction, except ISAF events or when international juries are appointed by the ISAF under rule 88.2(b).

APPENDIX A SCORING

See rule 89.3.

A1 NUMBER OF COURSE RACES

The number of course races scheduled and the number required to be completed to constitute a series shall be stated in the sailing instructions.

A2 OVERALL AND SERIES SCORES

A2.1 Overall Scores

- B8.1** If an event includes more than one discipline or format the sailing instructions shall state how the overall score is to be calculated.

A2.2 Series Scores

- B8.2** Each board's series score shall be the total of her race, elimination series or speed round scores with the number of her worst scores excluded as follows:

<i>Course races, speed rounds</i>	<i>Slalom and expression elimination series</i>	<i>Number excluded</i>
1–3	1–2	0
4–6	3–4	1
7–10	5–7	2
11–15	8 or more	3
16 or more		4

If a board has two or more equal worst scores, the score(s) for the race(s) sailed earliest in the series shall be excluded. The board with the lowest series score wins and others shall be ranked accordingly. Rules A4.4, A4.5 and A4.6 contain exceptions to this rule.

A3 STARTING TIMES AND FINISHING PLACES

The time of a board's starting signal shall be her starting time, and the order in which boards *finish* a race shall determine their finishing

places. However, when a handicap or rating system is used a board's corrected time shall determine her finishing place.

A4 LOW POINT AND ALTERNATIVE SYSTEMS

A4.1 Each board *starting* and *finishing* and not thereafter retiring, being
B8.3 penalized or given redress shall be scored points as follows:

<i>Finishing place</i>	<i>Low Point System</i>	<i>Alternative System</i>
First	1	0.7
Second	2	2
Third	3	3
Each place thereafter	Add 1 point	Add 1 point

A4.2 A board that did not *start*, did not *finish*, retired after *finishing* or was
B8.3 disqualified shall be scored points for the finishing place one more than the number of boards entered in the series or, in an elimination series, the number of boards in that heat. A board penalized under rule 30.2 shall be scored points as provided in rule 44.3(c).

A4.3 Uncompleted Heat

B8.4 When a heat cannot be completed, the points for the unscored places shall be added together and divided by the number of places in that heat. The resulting number of points, to the nearest tenth of a point (0.05 to be rounded upward), shall be given to each board entered in the heat.

A4.4 Scoring a Final Series in Slalom Racing

B8.5 (a) If three final races are completed, a board's series score in the final shall be the total of her race scores excluding her worst score. Otherwise her series score shall be the total of her race scores.

(b) A board that did not *start*, did not *finish*, retired after *finishing* or was disqualified from a final race shall be scored points equal to the total number of boards entered in the final.

A4.5 Expression Competition Scoring

B8.6 (a) Expression competition shall be scored by a panel of three judges. However, the panel may have a greater odd number of

members, and there may be two such panels. Each judge shall give points for each manoeuvre based on the scale stated in the sailing instructions.

- (b) The criteria of scoring shall be decided by the race committee and announced on the official notice board not later than 30 minutes before the starting signal for the first heat.
- (c) A board's heat standing shall be determined by adding together the points given by each judge. The board with the highest score wins and others shall be ranked accordingly.
- (d) Both semifinal heats shall have been sailed for an elimination series to be valid.
- (e) Except for members of the race committee responsible for scoring the event, only competitors in the heat shall be allowed to see judges' score sheets for the heat. Each score sheet shall bear the full name of the judge.
- (f) Scoring decisions of the judges shall not be grounds for a request for redress by a board.

A4.6 Speed Competition

B8.7 The speeds of a board's fastest two runs in a round shall be averaged to determine her standing in that round. The board with the highest average wins and others shall be ranked accordingly.

A5 SCORES DETERMINED BY THE RACE COMMITTEE

B2.1 A board that did not *start*, comply with rule 30.2 or 30.3, or *finish*, or retires after *finishing*, shall be scored accordingly by the race committee without a hearing. Only the protest committee may take other scoring actions that worsen a board's score.

A6 CHANGES IN PLACES AND SCORES OF OTHER BOARDS

A6.1 If a board is disqualified from a race or retires after *finishing*, each board with a worse finishing place shall be moved up one place.

A6.2 If the protest committee decides to give redress by adjusting a board's score, the scores of other boards shall not be changed unless the protest committee decides otherwise.

A7 RACE TIES

If boards are tied at the finishing line or if a handicap or rating system is used and boards have equal corrected times, the points for the place for which the boards have tied and for the place(s) immediately below shall be added together and divided equally. Boards tied for a race prize shall share it or be given equal prizes.

A8 SERIES TIES**B8.8****A8.1 Racing and Speed Competition**

- (a) If there is a series score tie between two or more boards, it shall be broken in favour of the board(s) with the best single excluded race score(s).
- (b) If a tie remains between two or more boards, each board's race scores shall be listed in order of best to worst, and at the first point(s) where there is a difference the tie shall be broken in favour of the board(s) with the best score(s). These scores shall be used even if some of them are excluded scores.
- (c) If a tie still remains between two or more boards, they shall be ranked in order of their scores in the last race. Any remaining ties shall be broken by using the tied boards' scores in the next-to-last race and so on until all ties are broken. These scores shall be used even if some of them are excluded scores.

A8.2 Expression Competition

- (a) In a heat, if there is a tie in the total points given by one or more judges, it shall be broken in favour of the board with the higher single score in the priority category. If the categories are weighted equally, in wave performance competition the tie shall be broken in favour of the board with the higher single score in wave riding, and in freestyle competition in favour of the board with the higher score for overall impression. If a tie remains, in wave performance competition it shall be broken in favour of the board with the higher single score in the category without priority, and in freestyle competition it shall stand as the final result.
- (b) If there is a tie in the series score, it shall be broken in favour of the board that scored better more times than the other

board. All scores shall be used even if some of them are excluded scores.

- (c) If a tie still remains, the heat shall be resailed. If this is not possible, the tie shall stand as the final result.

A9 RACE SCORES IN A SERIES LONGER THAN A REGATTA

For a series that is held over a period of time longer than a regatta, a board that came to the starting area but did not *start*, did not *finish*, retired after *finishing* or was disqualified shall be scored points for the finishing place one more than the number of boards that came to the starting area. A board that did not come to the starting area shall be scored points for the finishing place one more than the number of boards entered in the series.

A10 GUIDANCE ON REDRESS

If the protest committee decides to give redress by adjusting a board's score for a race, it is advised to consider scoring her

- (a) points equal to the average, to the nearest tenth of a point (0.05 to be rounded upward), of her points in all the races in the series except the race in question;
- (b) points equal to the average, to the nearest tenth of a point (0.05 to be rounded upward), of her points in all the races before the race in question; or
- (c) points based on the position of the board in the race at the time of the incident that justified redress.

A11 SCORING ABBREVIATIONS

These abbreviations are recommended for recording the circumstances described:

DNC	Did not <i>start</i> ; did not come to the starting area
DNS	Did not <i>start</i> (other than DNC and OCS)
OCS	Did not <i>start</i> ; on the course side of the starting line at her starting signal and failed to <i>start</i> , or broke rule 30.1
ZFP	20% penalty under rule 30.2
BFD	Disqualification under rule 30.3
DNF	Did not <i>finish</i>
RAF	Retired after <i>finishing</i>
DSQ	Disqualification

DNE	Disqualification (other than DGM) not excludable under rule 89.3(b)
DGM	Disqualification under rule 69.1(b)(2); not excludable
RDG	Redress given

APPENDIX F

APPEALS PROCEDURES

See rule 70. A national authority may change this appendix by prescription but it shall not be changed by sailing instructions.

F1 APPEALS AND REQUESTS

Appeals, requests by protest committees for confirmation or correction of their decisions, and requests for interpretations of the *rules* shall be made to the national authority of the venue.

F2 SUBMISSION OF DOCUMENTS

F2.1 Within 15 days of receiving the protest committee's written decision or its decision not to reopen a hearing, the appellant shall send an appeal and a copy of the protest committee's decision to the national authority. The appeal shall state why the appellant believes the protest committee's decision or its procedures were incorrect.

F2.2 The appellant shall also send, with the appeal or as soon as possible thereafter, all of the following documents that are available to her:

- (a) the written *protest(s)* or request(s) for redress;
- (b) a diagram, prepared or endorsed by the protest committee, showing the positions and tracks of all boards involved, the course to the next *mark* and the required side, the force and direction of the wind, and, if relevant, the depth of water and direction and speed of any current;
- (c) the notice of race, the sailing instructions, any other conditions governing the event, and any changes to them;
- (d) any additional relevant documents; and
- (e) the names, postal and e-mail addresses, and telephone numbers of all *parties* to the hearing and the protest committee chairman.

F2.3 A request from a protest committee for confirmation or correction of its decision shall be sent within 15 days of the decision and shall include the decision and the documents listed in rule F2.2. A request for an interpretation of the *rules* shall include assumed facts.

F3 RESPONSIBILITIES OF NATIONAL AUTHORITY AND PROTEST COMMITTEE

Upon receipt of an appeal or a request for confirmation or correction, the national authority shall send to the *parties* and protest committee copies of the appeal or request and the protest committee's decision. It shall ask the protest committee for any relevant documents listed in rule F2.2 not sent by the appellant or the protest committee, and the protest committee shall promptly send them to the national authority. When the national authority has received them it shall send copies to the *parties*.

F4 COMMENTS

The *parties* and protest committee may make comments on the appeal or request or on any of the documents listed in rule F2.2 by sending them in writing to the national authority. Comments on any document shall be made within 15 days of receiving it from the national authority. The national authority shall send copies of the comments to the *parties* and protest committee as appropriate.

F5 INADEQUATE FACTS; REOPENING

The national authority shall accept the protest committee's finding of facts except when it decides they are inadequate. In that case it shall require the committee to provide additional facts or other information, or to reopen the hearing and report any new finding of facts, and the committee shall promptly do so.

F6 WITHDRAWING AN APPEAL

An appellant may withdraw an appeal before it is decided by accepting the protest committee's decision.

APPENDIX G

IDENTIFICATION ON SAILS

See rule 77.

G1 ISAF INTERNATIONAL CLASS BOARDS**G1.1 Identification**

Every board of an ISAF International Class or Recognized Class shall carry on her mainsail and, as provided in rules G1.3(d) and G1.3(e) for letters and numbers only, on her spinnaker and headsail

- (a) the insignia denoting her class. The insignia shall not refer to **B2.4** anything other than the manufacturer or class and shall not consist of more than two letters and three numbers or an abstract design;
- (b) at all international events, except when the boards are provided to all competitors, national letters denoting her national authority from the table below. For the purposes of this rule, international events are ISAF events, world and continental championships, and events described as international events in their notices of race and sailing instructions; and
- (c) a sail number of no more than four digits allotted by her national authority or, when so required by the class rules, by the international class association. The four-digit limitation does not apply to classes whose ISAF membership or recognition took effect before 1 April 1997. Alternatively, if permitted in the class rules, an owner may be allotted a personal sail number by the relevant issuing authority, which may be used on all his boards in that class.

Sails measured before 31 March 1999 shall comply with rule G1.1 or with the rules applicable at the time of measurement.

NATIONAL SAIL LETTERS

<i>National authority</i>	<i>Letters</i>	<i>National authority</i>	<i>Letters</i>
Algeria	ALG	Finland	FIN
American Samoa	ASA	France	FRA
Andorra	AND	FYRO Macedonia	MKD
Angola	ANG	Germany	GER
Antigua	ANT	Great Britain	GBR
Argentina	ARG	Greece	GRE
Australia	AUS	Grenada	GRN
Austria	AUT	Guam	GUM
Azerbaijan	AZE	Guatemala	GUA
Bahamas	BAH	Hong Kong	HKG
Bahrain	BRN	Hungary	HUN
Barbados	BAR	Iceland	ISL
Belarus	BLR	India	IND
Belgium	BEL	Indonesia	INA
Bermuda	BER	Ireland	IRL
Brazil	BRA	Israel	ISR
British Virgin Islands	IVB	Italy	ITA
Bulgaria	BUL	Jamaica	JAM
Canada	CAN	Japan	JPN
Cayman Islands	CAY	Kazakhstan	KAZ
Chile	CHI	Kenya	KEN
China, PR	CHN	Korea	KOR
Chinese Taipei	TPE	Kuwait	KUW
Columbia	COL	Latvia	LAT
Cook Islands	COK	Lebanon	LIB
Croatia	CRO	Libya	LBA
Cuba	CUB	Liechtenstein	LIE
Cyprus	CYP	Lithuania	LTU
Czech Republic	CZE	Luxembourg	LUX
Denmark	DEN	Malaysia	MAS
Dominican Republic	DOM	Malta	MLT
Ecuador	ECU	Mauritius	MRI
Egypt	EGY	Mexico	MEX
El Salvador	ESA	Micronesia	FSM
Estonia	EST	Moldova	MDA
Fiji	FIJ	Monaco	MON

<i>National authority</i>	<i>Letters</i>	<i>National authority</i>	<i>Letters</i>
Morocco	MAR	Singapore	SIN
Myanmar	MYA	Slovak Republic	SVK
Namibia	NAM	Slovenia	SLO
The Netherlands	NED	Solomon Islands	SOL
Netherlands Antilles	AHO	South Africa	RSA
New Zealand	NZL	Spain	ESP
Norway	NOR	Sri Lanka	SRI
Pakistan	PAK	St Lucia	LCA
Papua New Guinea	PNG	Sweden	SWE
Paraguay	PAR	Switzerland	SUI
Peru	PER	Tahiti	TAH
Philippines	PHI	Thailand	THA
Poland	POL	Trinidad & Tobago	TRI
Portugal	POR	Tunisia	TUN
Puerto Rico	PUR	Turkey	TUR
Qatar	QAT	Ukraine	UKR
Romania	ROM	United Arab Emirates	UAE
Russia	RUS	United States of America	USA
Samoa	SAM	Uruguay	URU
San Marino	SMR	US Virgin Islands	ISV
Serbia and Montenegro	SCG	Venezuela	VEN
Seychelles	SEY	Zimbabwe	ZIM

G1.2 Specifications

- (a) National letters and sail numbers shall be in capital letters and Arabic numerals, clearly legible and of the same colour. Commercially available typefaces giving the same or better legibility than Helvetica are acceptable.
- (b) The height of characters and space between adjoining characters on the same and opposite sides of the sail shall be related to the board's overall length as follows:

<i>Overall length</i>	<i>Minimum height</i>	<i>Minimum space between characters and from edge of sail</i>
under 3.5 m	230 mm	45 mm
3.5 m–8.5 m	300 mm	60 mm
8.5 m–11 m	375 mm	75 mm
over 11 m	450 mm	90 mm

G1.3 Positioning

Class insignia, national letters and sail numbers shall be positioned as follows:

(a) The class insignia shall be displayed once on each side of the sail in the area above a line projected at right angles from a point on the luff of the sail one-third of the distance from the head to the wishbone. The national letters and sail numbers shall be in the central third of that part of the sail above the wishbone, clearly separated from any advertising, and placed at different heights on the two sides of the sail, those on the starboard side being uppermost.

(b) The class insignia shall be placed above the national letters. If the class insignia is of such a design that two of them coincide when placed back to back on both sides of the sail, they may be so placed.

G2 OTHER BOARDS

Other boards shall comply with the rules of their national authority or class association in regard to the allotment, carrying and size of insignia, letters and numbers. Such rules shall, when practicable, conform to the above requirements.

G3 CHARTERED OR LOANED BOARDS

When so stated in the notice of race or sailing instructions, a board chartered or loaned for an event may carry national letters or a sail number in contravention of her class rules.

G4 WARNINGS AND PENALTIES

When a protest committee finds that a board has broken a rule of this appendix it shall either warn her and give her time to comply or penalize her.

G5 CHANGES BY CLASS RULES

ISAF classes may change the rules of this appendix provided the changes have first been approved by the ISAF.

APPENDIX H

WEIGHING CLOTHING AND EQUIPMENT

See rule 43. This appendix shall not be changed by sailing instructions or prescriptions of national authorities.

- H1** Items of clothing and equipment to be weighed shall be arranged on a rack. After being saturated in water the items shall be allowed to drain freely for one minute before being weighed. The rack must allow the items to hang as they would hang from clothes hangers, so as to allow the water to drain freely. Pockets that have drain-holes that cannot be closed shall be empty, but pockets or items that can hold water shall be full.
- H2** When the weight recorded exceeds the amount permitted, the competitor may rearrange the items on the rack and the measurer shall again soak and weigh them. This procedure may be repeated a second time if the weight still exceeds the amount permitted.
- H3** A competitor wearing a dry-suit may choose an alternative means of weighing the items.
- (a) The dry-suit and items of clothing and equipment that are worn outside the dry-suit shall be weighed as described above.
 - (b) Clothing worn underneath the dry-suit shall be weighed as worn while *rac*ing, without draining.
 - (c) The two weights shall be added together.

APPENDIX J

NOTICE OF RACE AND SAILING INSTRUCTIONS

See rules 88.2(a) and 89.2. The term 'race' includes a regatta or other series of races.

J1 NOTICE OF RACE CONTENTS

J1.1 The notice of race shall include the following information:

- (1) the title, place and dates of the race and name of the organizing authority;
- (2) that the race will be governed by the *rules* as defined in *The Racing Rules of Sailing*;
- (3) a list of any other documents that will govern the event (for example, *The Equipment Rules of Sailing*, to the extent that they apply), stating where or how each document or a copy of it may be seen;
- (4) the classes to race, any handicap or rating system that will be used and the classes to which it will apply, conditions of entry and any restrictions on entries;
- (5) the times of registration and warning signals for the practice race or first race, and succeeding races if known.

J1.2 The notice of race shall include any of the following that would help competitors decide whether to attend the event or that conveys other information they will need before the sailing instructions become available:

- (1) identification of any racing rules that will be changed, a summary of the changes, and a statement that the changes will appear in full in the sailing instructions (see rule 86);
- (2) that advertising will be restricted to Category A (see ISAF Regulation 20) and other information related to Regulation 20;
- (3) that the ISAF Sailor Classification Code will apply;
- (4) for an international event, any prescriptions of the national authority that may require advance preparation;

- (5) the procedure for advance registration or entry, including fees and any closing dates;
- (6) an entry form, to be signed by the board's owner or owner's representative, containing words such as 'I agree to be bound by *The Racing Rules of Sailing* and by all other *rules* that govern this event';
- (7) measurement procedures or requirements for measurement or rating certificates;
- (8) the time and place at which the sailing instructions will be available;
- (9) any changes to class rules, referring specifically to each rule and stating the change;
- (10) the courses to be sailed;
- (11) the penalty for breaking a rule of Part 2, other than the Turn **B2.1** Penalty;
- (12) denial of the right of appeal, subject to rule 70.4;
- (13) the scoring system, if different from the Low Point System in Appendix A, the number of races scheduled and the minimum number that must be completed to constitute a series;
- (14) prizes.

J2 SAILING INSTRUCTION CONTENTS

J2.1 The sailing instructions shall include the following information:

- (1) that the race will be governed by the *rules* as defined in *The Racing Rules of Sailing*;
- (2) a list of any other documents that will govern the event (for example, *The Equipment Rules of Sailing*, to the extent that they apply);
- (3) the schedule of races, the classes to race and times of warning signals for each class;
- (4) the course(s) to be sailed, or a list of *marks* from which the course will be selected and, if relevant, how courses will be signalled;
- (5) descriptions of *marks*, including starting and finishing *marks*, stating the order and side on which each is to be left and identifying all rounding *marks* (see rule 28.1);

- (6) descriptions of the starting and finishing lines, class flags and any special signals to be used;
- (7) the time limit, if any, for *finishing*;
- (8) the handicap or rating system to be used, if any, and the classes to which it will apply;
- (9) the scoring system, included by reference to Appendix A, to class rules or other *rules* governing the event, or stated in full. State the number of races scheduled and the minimum number that must be completed to constitute a series. State the scale required in rule A4.5 if applicable;
- (10) the starting system in racing competition.

B3.2

J2.2 The sailing instructions shall include those of the following that will apply:

- (1) that advertising will be restricted to Category A (see ISAF Regulation 20) and other information related to Regulation 20;
- (2) that the ISAF Sailor Classification Code will apply;
- (3) replacement of the relevant rules of Part 2 with the *International Regulations for Preventing Collisions at Sea* or other government right-of-way rules, the time(s) or place(s) they will apply, and any night signals to be used by the race committee;
- (4) changes to the racing rules permitted by rule 86, referring specifically to each rule and stating the change (if rule 86.2 applies, state the authorization);
- (5) changes to the prescriptions of the national authority (see rule 87);
- (6) at an international event, a copy in English of the prescriptions of the national authority that will apply;
- (7) changes to class rules, referring specifically to each rule and stating the change;
- (8) restrictions controlling changes to boards when supplied by the organizing authority;
- (9) the registration procedure;
- (10) measurement or inspection procedure;
- (11) location(s) of official notice board(s);

- (12) procedure for changing the sailing instructions; procedure for **B2.3** giving oral instructions;
- (13) safety requirements, such as requirements and signals for personal buoyancy, check-in at the starting area, and check-out and check-in ashore;
- (14) declaration requirements;
- (15) signals to be made ashore and location of signal station(s);
- (16) the racing area (a chart is recommended);
- (17) approximate course length and approximate length of windward legs;
- (18) description of any area designated by the race committee to be an *obstruction* (see the definition *Obstruction*);
- (19) the time limit, if any, for boards other than the first board to *finish*;
- (20) time allowances;
- (21) the location of the starting area and any applicable restrictions;
- (22) any special procedures or signals for individual or general recall;
- (23) boards identifying *mark* locations;
- (24) any special procedures or signals for changing the position of a *mark* after the start;
- (25) any special procedures for shortening the course or for *finishing* a shortened course;
- (26) restrictions on use of support boats, radios, etc.; and on outside assistance provided to a board that is not *racing*;
- (27) the penalty for breaking a rule of Part 2, other than the Turn **B2.1** Penalty;
- (28) Deleted.
- B7.6**
- (29) Not applicable to windsurfing.
- B2.1**
- (30) protest procedure and times and place of hearings;
- (31) if rule N1.4(b) will apply, the time limit for requesting a hearing under that rule;

- (32) denial of the right of appeal, subject to rule 70.4;
- (33) the national authority's approval of the appointment of an international jury under rule 90(b);
- (34) Not applicable to windsurfing.
- (35) the minimum number of boards appearing in the starting area required for a race to be started;
- (36) when and where races *postponed* or *abandoned* for the day will be resailed;
- (37) tides and currents;
- (38) prizes;
- (39) other commitments of the race committee and obligations of boards.

APPENDIX K

NOTICE OF RACE GUIDE

This guide, adapted for windsurfing, provides a notice of race designed primarily for major championship regattas for one or more classes. It therefore will be particularly useful for world, continental and national championships and other events of similar importance. It can be downloaded from the ISAF website (www.sailing.org) as a basic text for producing a notice of race for any particular event.

The guide can also be useful for other events. However, for such events some of the paragraphs will be unnecessary or undesirable. Organizing authorities should therefore be careful in making their choices.

This guide relates closely to Appendix L, Sailing Instructions Guide, and its extended version Appendix LE on the ISAF website, the introduction to which contains principles that also apply to a notice of race.

To use this guide, first review rule J1 and decide which paragraphs will be needed. Paragraphs that are required by rule J1.1 are marked with an asterisk (). Delete all inapplicable or unnecessary paragraphs. Select the version preferred where there is a choice. Follow the directions in the left margin to fill in the spaces where a solid line (_____) appears and select the preferred wording if a choice or option is shown in brackets ([. . .]).*

After deleting unused paragraphs, renumber all paragraphs in sequential order. Be sure that paragraph numbers are correct where one paragraph refers to another.

The items listed below, when applicable, should be distributed with the notice of race, but should not be included as numbered paragraphs within the notice.

- 1 An entry form, to be signed by the board's owner or owner's representative, containing words such as 'I agree to be bound by The Racing Rules of Sailing and by all other rules that govern this event.'*

- 2 In an international event, the applicable prescriptions of the national authority in English.*
- 3 List of sponsors, if appropriate.*
- 4 Lodging and camping information.*
- 5 Description of meal facilities.*
- 6 Race committee and [protest committee] [jury] members.*
- 7 Special mooring or storage requirements.*
- 8 Sail and board repair facilities and ship's chandlers.*
- 9 Charter board availability.*

On separate lines, insert the full name of the regatta, the inclusive dates from measurement or the practice race until the final race or closing ceremony, the name of the organizing authority, and the city and country.

NOTICE OF RACE

1 RULES

- 1.1*** The regatta will be governed by the rules as defined in *The Racing Rules of Sailing*.

- 1.2** The following prescriptions of the _____ national authority will apply [and will be stated in full in the sailing instructions]. [Of these, those that may require advance preparation are stated in full below.]

(OR)

Use only if the national authority for the venue of the event has not adopted a prescription to rule 87.

- 1.2** No national authority prescriptions will apply.

List by name any other documents that govern the

- 1.3*** _____ will apply.

event; for example, The Equipment Rules of Sailing, to the extent that they apply.

See rule 86. Insert the rule number(s) and summarize the changes.

Inform competitors of proper changes. Insert the rule number(s) and class name. Make a separate statement for the rules of each class.

See ISAF Regulation 20. Include other applicable information related to Regulation 20.

Insert the class(es).

Insert the class(es) and eligibility requirements.

Insert the postal, fax and e-mail addresses and entry closing date.

Insert any conditions.

Insert any restrictions.

1.4 Racing rule(s) _____ will be changed as follows: _____. The changes will appear in full in the sailing instructions.

1.5 Rule(s) _____ of the _____ class rules [will not apply] [is (are) changed as follows: _____].

1.6 If there is a conflict between languages the English text will take precedence.

2 ADVERTISING

Advertising will be restricted to Category A.

3* ELIGIBILITY AND ENTRY

3.1 The regatta is open to all boards of the _____ class(es).

(OR)

3.1 The regatta is open to boards of the _____ class(es) that _____.

3.2 Eligible boards may enter by completing the attached form and sending it, together with the required fee, to _____ by _____.

3.3 Late entries will be accepted under the following conditions: _____.

3.4 The following restrictions on the number of boards apply: _____.

4 CLASSIFICATION

The ISAF Sailor Classification Code will apply.

5 FEES

Insert all required fees for racing.

5.1 Required fees are as follows:

<i>Class</i>	<i>Fee</i>
_____	_____
_____	_____
_____	_____

Insert optional fees (e.g. for social events).

5.2 Other fees:

6 QUALIFYING SERIES AND FINAL SERIES

The regatta will consist of a qualifying series and a final series.

Use only when a class is divided into fleets racing a qualifying series and a final series.

7 SCHEDULE

Insert the day, date and times.

7.1* Registration:

Day and date _____
From _____ To _____

Insert the day, date and times.

7.2 Measurement and inspection:

Day and date _____
From _____ To _____

<i>Revise as desired and insert the dates and classes. Include a practice race if any. When the series consists of qualifying races and final races, specify them. The schedule can also be given in an attachment.</i>	7.3*	Dates of racing: <i>Date</i> <i>Class</i> _____ <i>Class</i> _____ _____ racing racing _____ racing reserve day _____ reserve day racing _____ racing racing _____ racing racing
<i>Insert the classes and numbers.</i>	7.4	Number of races: <i>Class</i> <i>Number</i> <i>Races per day</i> _____ _____ _____ _____ _____ _____
<i>Insert the time.</i>	7.5*	The scheduled time of the warning signal for the [practice race] [first race] [each day] is _____.
	8	MEASUREMENTS Each board shall produce a valid [measurement] [rating] certificate.
	(OR)	Each board shall produce a valid [measurement] [rating] certificate. In addition the following measurements [may] [will] be taken: _____.
<i>List the measurements with appropriate references to the class rules.</i>		
	9	SAILING INSTRUCTIONS The sailing instructions will be available after _____ on _____ at _____.
<i>Insert the time, date and location.</i>		
	10	VENUE
<i>Insert a number or letter. Provide a marked map with driving instructions.</i>	10.1	Attachment _____ shows the location of the regatta harbour.
<i>Insert a number or letter. Provide a marked map or chart.</i>	10.2	Attachment _____ shows the location of the racing areas.

	11	THE COURSES <i>Include the description.</i> <i>Insert a number or letter. A method of illustrating various courses is shown in Addendum A of Appendix L or LE. Insert the course length if applicable.</i>	The courses to be sailed will be as follows: _____. (OR) The diagrams in Attachment _____ show the courses, including the approximate angles between legs, the order in which marks are to be passed, and the side on which each mark is to be left. [The approximate course length will be _____.]
	12	PENALTY SYSTEM	
	12.1	<i>Include only when the Turn Penalty will not be used. Describe the penalties.</i>	The penalties are as follows: _____.
	12.2	<i>Include only if the protest committee is an international jury or another provision of rule 70.4 applies. Use 'jury' only if referring to an international jury.</i>	Decisions of the [protest committee] [jury] will be final as provided in rule 70.4.
	13	SCORING	
	13.1	<i>Include only if the Low Point System is replaced by the Alternative System.</i>	The Alternative System of Appendix A will apply.
	(OR)		
	13.1	<i>Include only if neither of the Appendix A scoring systems will be used. Describe the system.</i>	The scoring system is as follows: _____.
	13.2	<i>Describe the method if rule A1.2 is applicable.</i>	The overall score is calculated is follows: _____.
	13.3	<i>Include for expression competition.</i>	The scale for manoeuvres is as follows: _____.

- Insert the number.*
- 13.4** _____ races are required to be completed to constitute a series.
- 14 SUPPORT BOATS**
Support boats shall be marked with _____.
- Insert the identification markings. National letters are suggested for international events.*
- 15 BERTHING**
Boards shall be kept in their assigned places in the boat park.
- 16 PRIZES**
Prizes will be given as follows: _____.
- When perpetual trophies will be awarded state their complete names.*
- 17 DISCLAIMER OF LIABILITY**
Competitors participate in the regatta entirely at their own risk. See rule 4, Decision to Race. The organizing authority will not accept any liability for material damage or personal injury or death sustained in conjunction with or prior to, during, or after the regatta.
- 18 INSURANCE**
Each participating board shall be insured with valid third-party liability insurance with a minimum cover of _____ per event or the equivalent.
- Insert the currency and amount.*
- 19 FURTHER INFORMATION**
For further information please contact _____.
- Insert necessary contact information: person or organization, address, telephone, fax, e-mail.*

APPENDIX L

SAILING INSTRUCTIONS GUIDE

This guide, adapted for windsurfing, provides a set of tested sailing instructions designed primarily for major championship regattas for one or more classes. It therefore will be particularly useful for world, continental and national championships and other events of similar importance. The guide can also be useful for other events; however, for such events some of these instructions will be unnecessary or undesirable. Race officers should therefore be careful in making their choices.

An expanded version of the guide, Appendix LE, is available on the ISAF website (www.sailing.org). It contains provisions applicable to the largest and most complicated multi-class events, as well as variations on several of the sailing instructions recommended in this appendix. It will be revised from time to time, to reflect advances in race management techniques as they develop, and can be downloaded as a basic text for producing the sailing instructions for any particular event. Appendix L can also be downloaded from the ISAF website.

The principles on which all sailing instructions should be based are as follows:

- 1 They should include only two types of statement: the intentions of the race committee and the obligations of competitors.*
- 2 They should be concerned only with racing. Information about social events, assignment of moorings, etc., should be provided separately.*
- 3 They should not change the racing rules except when clearly desirable.*
- 4 They should not repeat or restate any of the racing rules.*
- 5 They should not repeat themselves.*
- 6 They should be in chronological order; that is, the order in which the competitor will use them.*
- 7 They should, when possible, use words or phrases from the racing rules.*

To use this guide, first review rule J2 and decide which instructions will be needed. Instructions that are required by rule J2.1 are marked with an asterisk (*). Delete all inapplicable or unnecessary instructions. Select the version preferred where there is a choice. Follow the directions in the left margin to fill in the spaces where a solid line (_____) appears and select the preferred wording if a choice or option is shown in brackets ([. . .]).

After deleting unused instructions, renumber all instructions in sequential order. Be sure that instruction numbers are correct where one instruction refers to another.

On separate lines, insert the full name of the regatta, the inclusive dates from measurement or the practice race until the final race or closing ceremony, the name of the organizing authority, and the city and country.

SAILING INSTRUCTIONS

1 RULES

1.1* The regatta will be governed by the rules as defined in *The Racing Rules of Sailing*.

Insert the name. State the relevant prescriptions in full.

1.2 The following prescriptions of the _____ national authority will apply: _____.

(OR)

Use only if the national authority for the venue of the event has not adopted a prescription to rule 87.

1.2 No national authority prescriptions will apply.

List by name any other documents that govern the event; for example, The Equipment Rules of Sailing, to the extent that they apply.

1.3* _____ will apply.

See rule 86. Insert the rule number(s) and state the changes.

1.4 Racing rule(s) _____ will be changed as follows: _____.

Insert the rule number(s) and class name. Make a separate statement for the rules of each class.

1.5 Rule(s) _____ of the _____ class rules [will not apply] [is (are) changed as follows: _____].

1.6 If there is a conflict between languages the English text will take precedence.

2 NOTICES TO COMPETITORS

Insert the location(s).

Notices to competitors will be posted on the official notice board(s) located at _____.

3 SAILING INSTRUCTIONS

Change the times if different.

3.1 Any change to the sailing instructions will be posted before 0900 on the day it will take effect, except that any change to the schedule of races will be posted by 2000 on the day before it will take effect.

State the procedure.

3.2 Oral sailing instructions will be given as follows: _____.

4 SIGNALS MADE ASHORE

Insert the location.

4.1 Signals made ashore will be displayed at _____.

Insert the number of minutes.

4.2 When flag AP is displayed ashore, '1 minute' is replaced with 'not less than _____ minutes' in the race signal AP.

(OR)

Insert the number of minutes.

4.2 Flag D with a sound means 'The warning signal will be made not less than _____ minutes after flag D is displayed. [Boards are requested not to leave the harbour until this signal is made.]'

Delete if a class rule applies.

- 4.3** When flag Y is displayed ashore, rule 40.1 applies at all times while afloat. This changes the Part 4 preamble.

5 SCHEDULE OF RACES

Revise as desired and insert the dates and classes. Include a practice race if any. When the series consists of qualifying races and final races, specify them. The schedule can also be given in an attachment.

- 5.1*** Dates of racing:
- | Date | Class | Class |
|-------|-------------|-------------|
| _____ | racing | racing |
| _____ | racing | reserve day |
| _____ | reserve day | racing |
| _____ | racing | racing |
| _____ | racing | racing |

Insert the classes and numbers.

- 5.2*** Number of races:
- | Class | Number | Races per day |
|-------|--------|---------------|
| _____ | _____ | _____ |
| _____ | _____ | _____ |

- (a) Reserve days may be used if races are not completed as scheduled or if the race committee considers it unlikely that races will be completed as scheduled.
- (b) One extra race per day may be sailed, provided that no class becomes more than one race ahead of schedule.

Insert the time.

- 5.3*** The scheduled time of the warning signal for the first race each day is _____.
- 5.4** When there has been a long postponement and when more than one race (or sequence of races, for two or more classes) will be held on the same day, the warning signal for the first race and each succeeding race will be made as soon as practicable. To alert boards that a race or sequence of races will begin soon, an orange flag will be displayed with one sound for at least

four minutes before a warning signal is displayed.

Insert the time.

- 5.5** On the last day of the regatta no warning signal will be made after _____.

6* CLASS FLAGS

Insert the classes and names or descriptions of the flags.

Class flags will be:

Class	Flag
_____	_____
_____	_____
_____	_____

7 RACING AREAS

Insert a number or letter.

Attachment _____ shows the location of racing areas.

8 THE COURSES

Insert a number or letter. A method of illustrating various courses is shown in Addendum A. Insert the course length if applicable.

- 8.1*** The diagrams in Attachment _____ show the courses, including the approximate angles between legs, the order in which marks are to be passed, and the side on which each mark is to be left. [The approximate course length will be _____.]
- 8.2** No later than the warning signal, the race committee signal boat will display the approximate compass bearing of the first leg.
- 8.3** When there is a gate, boards shall sail between the gate marks from the direction of the previous mark and round either gate mark.
- 8.4** Courses will not be shortened. This changes rule 32.

- Include only when changing positions of marks is impracticable.*
- 8.5** Legs of the course will not be changed after the preparatory signal. This changes rule 33.
- 9 MARKS**
- Change the mark numbers as needed and insert the descriptions of the marks. Use the second alternative when Marks 4S and 4P form a gate, with Mark 4S to be left to starboard and Mark 4P to port. Unless clear from the course diagrams, state which marks are rounding marks.*
- 9.1*** Marks 1, 2, 3 and 4 will be _____.
(OR)
- 9.1*** Marks 1, 2, 3, 4S and 4P will be _____.
(OR)
- Insert the descriptions of the marks.*
- 9.2** New marks, as provided in instruction 12.1, will be _____.
(OR)
- Describe the starting and finishing marks: for example, the race committee signal boat at the starboard end and a buoy at the port end. Instruction 11.2 will describe the starting line and instruction 13 the finishing line.*
- 9.3*** The starting and finishing marks will be _____.
(OR)
- 9.4** A race committee boat signalling a change of a leg of the course is a mark as provided in instruction 12.2.
- 10 AREAS THAT ARE OBSTRUCTIONS**
- Describe each area by its location and any easily recognized details of appearance.*
- The following areas are designated as obstructions: _____.

- 11 THE START**
- Include for racing competition. Insert the system number.*
- 11.1*** Races will be started by using rule 26.1, System _____.
(OR)
- Describe any starting system other than those stated in rule 26.1.*
- 11.1*** Races will be started as follows: _____. This changes rule 26.1.
- 11.2*** The starting line will be between staffs displaying orange flags on the starting marks.
(OR)
- 11.2*** The starting line will be between a staff displaying an orange flag on the starting mark at the starboard end and the port-end starting mark.
(OR)
- Insert the description.*
- 11.2*** The starting line will be _____.
(OR)
- 11.3** Boards whose warning signal has not been made shall avoid the starting area.
- 11.4** A board starting later than _____ minutes after her starting signal will be scored Did Not Start. This changes rule A4.
- 11.5** If any part of a board's hull, crew or equipment is on the course side of the starting line during the two minutes before her starting signal, the race committee will display flag V. It will be displayed until all boards have sailed completely to the pre-start side, but not after the starting signal.
- 12 CHANGE OF THE NEXT LEG OF THE COURSE**
- 12.1** To change the next leg of the course, the race committee will move the original

mark (or the finishing line) to a new position.

(OR)

12.1 To change the next leg of the course, the race committee will lay a new mark (or move the finishing line) and remove the original mark as soon as practicable. When in a subsequent change a new mark is replaced, it will be replaced by an original mark.

Reverse 'port' and 'starboard' when the mark is to be left to starboard.

12.2 Except at a gate, boards shall pass between the race committee boat signalling the change of the next leg and the nearby mark, leaving the mark to port and the race committee boat to starboard. This changes rule 28.1.

13* THE FINISH

The finishing line will be between staffs displaying orange flags on the finishing marks.

(OR)

The finishing line will be between a staff displaying an orange flag on the finishing mark at the starboard end and the port-end finishing mark.

(OR)

Insert the description.

The finishing line will be _____.

14 PENALTY SYSTEM

Include only when the Turn Penalty will not be used. Describe the penalties.

14.1 The penalties are as follows: _____.

14.2 A board that has taken a penalty under rule 44.1 shall complete an acknowledgment form at the race office within the protest time limit.

15 TIME LIMITS

Insert the classes and times. Omit the Mark 1 time limit if inapplicable.

15.1* Time limits are as follows:

<i>Class</i>	<i>Time limit</i>	<i>Mark 1 time limit</i>
_____	_____	_____
_____	_____	_____
_____	_____	_____

If no board has passed Mark 1 within the Mark 1 time limit the race will be abandoned.

Insert the time (or different times for different classes).

15.2 Boards failing to finish within _____ after the first board sails the course and finishes will be scored Did Not Finish. This changes rules 35, A4.1 and A4.2.

16 PROTESTS AND REQUESTS FOR REDRESS

16.1 Protest forms are available at the race office. Protests shall be delivered there within the protest time limit.

Change the time if different.

16.2 For each class, the protest time limit is 90 minutes after the last board has finished the last race of the day. [The same time limit applies to protests by the race committee and [protest committee] [jury] about incidents they observe in the racing area and to requests for redress. This changes rules 61.3 and 62.2.]

Change the posting time if different. Insert the jury room location and the time for the first hearing.

16.3 Notices will be posted within 30 minutes of the protest time limit to inform competitors of hearings in which they are parties or named as witnesses. Hearings will be held in the jury room, located at _____, beginning at _____.

16.4 Notices of protests by the race committee or [protest committee] [jury] will be

posted to inform boards under rule 61.1(b).

16.5 Breaches of instructions 11.3, 14.2, 18, 19 and 22 will not be grounds for a protest by a board. This changes rule 60.1(a). Penalties for these breaches may be less than disqualification if the [protest committee] [jury] so decides.

16.6 On the last day of the regatta a request for reopening a hearing shall be delivered

(a) within the protest time limit if the party requesting reopening was informed of the decision on the previous day;

(b) no later than 30 minutes after the party requesting reopening was informed of the decision on that day.

This changes rule 66.

Change the time if different.

Include only if the protest committee is an international jury or another provision of rule 70.4 applies.

16.7 Decisions of the [protest committee] [jury] will be final as provided in rule 70.4.

17 SCORING

Include only if the Low Point System is replaced by the Alternative System.

17.1* The Alternative System of Appendix A will apply.

(OR)

Include only if neither of the Appendix A scoring systems will be used. Describe the system.

17.1* The scoring system is as follows: _____.

Describe the method if rule A2.1 is applicable.

17.2* The overall score is calculated is follows: _____.

Include for expression competition.

17.3* The scale for manoeuvres is as follows: _____.

Insert the number for course racing.

17.4* _____ races are required to be completed to constitute a series.

Insert the procedure for check-out and check-in.

18 SAFETY REGULATIONS

18.1 Check-out and check-in: _____.

18.2 A board that retires from a race shall notify the race committee as soon as possible.

19 REPLACEMENT OF EQUIPMENT

Substitution of damaged or lost equipment will not be allowed unless approved by the race committee. Requests for substitution shall be made to the committee at the first reasonable opportunity.

20 EQUIPMENT AND MEASUREMENT CHECKS

A board or equipment may be inspected at any time for compliance with the class rules and sailing instructions. On the water, a board can be instructed by a race committee measurer to proceed immediately to a designated area for inspection.

21 OFFICIAL BOATS

Official boats will be marked as follows: _____.

Insert the descriptions. If appropriate, use different identification markings for boats performing different duties.

22 SUPPORT BOATS

22.1 Team leaders, coaches and other support personnel shall stay outside areas where boards are racing from the time of the pre-

paratory signal for the first class to start until all boards have finished or the race committee signals a postponement, general recall or abandonment.

Insert the identification markings. National letters are suggested for international events.

22.2 Support boats shall be marked with _____.

23 PRIZES

If perpetual trophies will be awarded state their complete names.

Prizes will be given as follows: _____.

24 DISCLAIMER OF LIABILITY

Competitors participate in the regatta entirely at their own risk. See rule 4, Decision to Race. The organizing authority will not accept any liability for material damage or personal injury or death sustained in conjunction with or prior to, during, or after the regatta.

25 INSURANCE

Insert the currency and amount.

Each participating board shall be insured with valid third-party liability insurance with a minimum cover of _____ per event or the equivalent.

ADDENDUM A

ILLUSTRATING THE COURSE

Shown here are diagrams of course shapes. Any course can be similarly shown. When there is more than one course, prepare a separate diagram for each course and state how each will be signalled.

A Windward-Leeward Course

Start – 1 – 2 – 1 – 2 – Finish

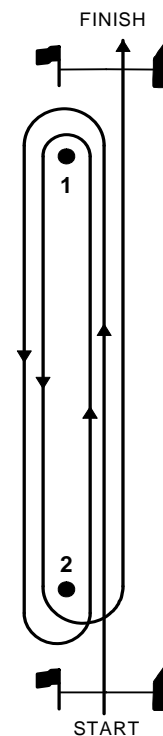

Options for this course include

- (1) increasing or decreasing the number of laps,*
- (2) deleting the final windward leg,*
- (3) using a gate instead of a leeward mark,*
- (4) using an offset mark at the windward mark, and*

- (5) using the leeward and windward marks as starting and finishing marks.

A Windward-Leeward-Triangle Course

Start – 1 – 2 – 3 – 1 – 3 – Finish

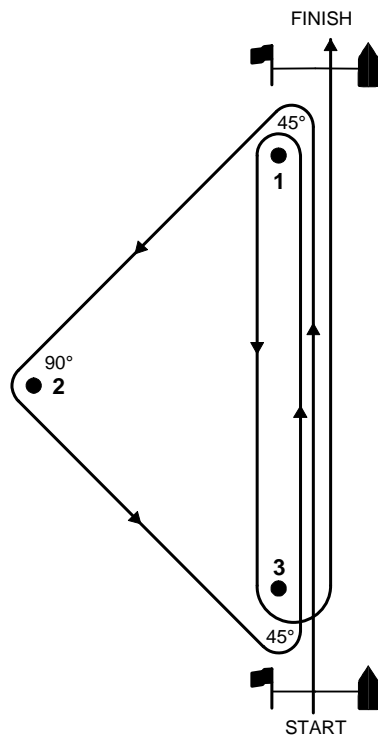

Options for this course include

- (1) increasing or decreasing the number of laps,
- (2) deleting the last windward leg,
- (3) varying the interior angles of the triangle (45° – 90° – 45° and 60° – 60° – 60° are common),
- (4) using a gate instead of a leeward mark for downwind legs (but not reaches),
- (5) using an offset mark at the beginning of downwind legs (but not reaches), and

- (6) using the leeward and windward marks as starting and finishing marks.

Be sure to specify the interior angle at each mark.

Trapezoid Courses

Start – 1 – 2 – 3 – 2 – 3 – Finish

Start – 1 – 4 – 1 – 2 – 3 – Finish

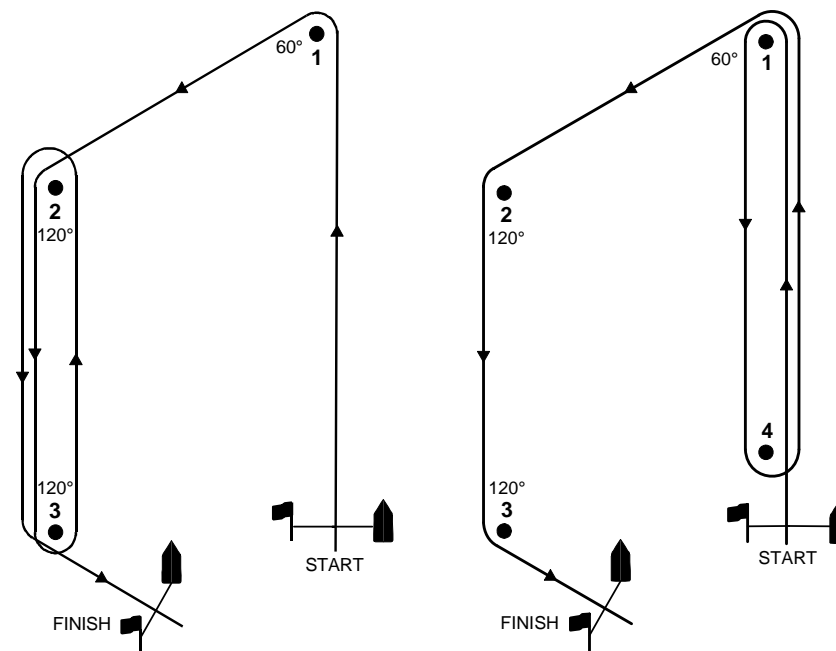

Options for these courses include

- (1) adding additional legs,
- (2) using gates instead of leeward marks for downwind legs (but not reaches),
- (3) varying the interior angles of the reaching legs,
- (4) using an offset mark at the beginning of downwind legs (but not reaches), and
- (5) finishing boards upwind rather than on a reach.

Be sure to specify the interior angle of each reaching leg. It is recommended that Mark 4 be different from the starting mark.

ADDENDUM B

BOARDS PROVIDED BY THE ORGANIZING AUTHORITY

The following sailing instruction is recommended when all boards will be provided by the organizing authority. It can be changed to suit the circumstances. When used, it should be inserted after instruction 3.

4 BOARDS

- 4.1** Boards will be provided for all competitors, who shall not modify them or cause them to be modified in any way except that
- a compass may be tied or taped to the hull or spars;
 - wind indicators, including yarn or thread, may be tied or taped anywhere on the board;
 - hulls, centreboards and rudders may be cleaned, but only with water;
 - adhesive tape may be used anywhere above the water line; and
 - all fittings or equipment designed to be adjusted may be adjusted, provided that the class rules are complied with.
- 4.2** All equipment provided with the board for sailing purposes shall be in the board while afloat.
- 4.3** The penalty for not complying with one of the above instructions will be disqualification from all races sailed in which the instruction was broken.
- 4.4** Competitors shall report any damage or loss of equipment, however slight, to the organizing authority's representative immediately after securing the board ashore. The penalty for breaking this instruction, unless the [protest committee] [jury] is satisfied that the competitor made a determined effort to comply, will be disqualification from the race most recently sailed.
- 4.5** Class rules requiring competitors to be members of the class association will not apply.

APPENDIX M

RECOMMENDATIONS FOR PROTEST COMMITTEES

This appendix is advisory only; in some circumstances changing these procedures may be advisable. It is addressed primarily to protest committee chairmen but may also help judges, jury secretaries, race committees and others connected with protest and redress hearings.

In a protest or redress hearing, the protest committee should weigh all testimony with equal care; should recognize that honest testimony can vary, and even be in conflict, as a result of different observations and recollections; should resolve such differences as best it can; should recognize that no board or competitor is guilty until a breach of a *rule* has been established to the satisfaction of the protest committee; and should keep an open mind until all the evidence has been heard as to whether a board or competitor has broken a *rule*.

M1 PRELIMINARIES (may be performed by race office staff)

- Receive the *protest* or request for redress.
- Note on the form the time the *protest* or request is delivered and the protest time limit.
- Inform each *party*, and the race committee when necessary, when and where the hearing will be held.

M2 BEFORE THE HEARING

Make sure that

- each *party* has a copy of or the opportunity to read the *protest* or request for redress and has had reasonable time to prepare for the hearing.
- no member of the protest committee is an *interested party*. Ask the *parties* whether they object to any member. When redress is requested under rule 62.1(a), a member of the race committee should not be a member of the protest committee.
- only one person from each board (or *party*) is present unless an interpreter is needed.

- all boards and people involved are present. If they are not, however, the committee may proceed under rule 63.3(b).
- boards' representatives were on board when required (rule 63.3(a)). When the *parties* were in different races, both organizing authorities must accept the composition of the protest committee (rule 63.8). In a measurement *protest* obtain the current class rules and identify the authority responsible for interpreting them (rule 64.3(b)).

M3 THE HEARING

M3.1 Check the validity of the *protest* or request for redress.

- Are the contents adequate (rule 61.2 or 62.1)?
- Was it delivered in time? If not, is there good reason to extend the time limit (rule 61.3 or 62.2)?
- When required, was the protestor involved in or a witness to the incident (rule 60.1(a))?
- When necessary, was 'Protest' hailed and, if required, a red flag displayed correctly (rule 61.1(a))?
- When the flag and hail were not necessary was the protestee informed?
- Decide whether the *protest* or request for redress is valid (rule 63.5).
- Once the validity of the *protest* or request has been determined, do not let the subject be introduced again unless truly new evidence is available.

M3.2 Take the evidence (rule 63.6).

- Ask the protestor and then the protestee to tell their stories. Then allow them to question one another. In a redress matter, ask the *party* to state the request.
- Invite questions from protest committee members.
- Make sure you know what facts each *party* is alleging before calling any witnesses. Their stories may be different.
- Allow anyone to give evidence. It is the *party* who normally decides which witnesses to call, although the protest committee may also call witnesses (rule 63.6). The question asked by a

party 'Would you like to hear N?' is best answered by 'It is your choice.'

- Call each *party*'s witnesses (and the protest committee's if any) one by one. Limit *parties* to questioning the witness(es) (they may wander into general statements).
- Invite the protestee to question the protestor's witness first (and vice versa). This prevents the protestor from leading his witness from the beginning.
- Allow a member of the protest committee who saw the incident to give evidence (rule 63.6) but only in the presence of the *parties*. The member may be questioned and may remain in the room (rule 63.3(a)).
- Try to prevent leading questions or hearsay evidence, but if that is impossible discount the evidence so obtained.
- Accept written evidence from a witness who is not available to be questioned only if all *parties* agree. In doing so they forego their rights to question that witness (rule 63.6).
- Ask one member of the committee to note down evidence, particularly times, distances, speeds, etc.
- Invite first the protestor and then the protestee to make a final statement of her case, particularly on any application or interpretation of the *rules*.

M3.3 Find the facts (rule 63.6).

- Write down the facts; resolve doubts one way or the other.
- Call back *parties* for more questions if necessary.
- When appropriate, draw a diagram of the incident using the facts you have found.

M3.4 Decide the *protest* or request for redress (rule 64).

- Base the decision on the facts found (if you cannot, find some more facts).
- In redress cases, make sure that no further evidence is needed from boards that will be affected by the decision.

M3.5 Inform the *parties* (rule 65).

- Recall the *parties* and read them the facts found, conclusions and *rules* that apply, and the decision. When time presses it is permissible to read the decision and give the details later.
- Give any *party* a copy of the decision on request. File the *protest* or request for redress with the committee records.

M4 REOPENING A HEARING (rule 66)

When a *party*, within the time limit, has asked for a hearing to be reopened, hear the *party* making the request, look at any video, etc., and decide whether there is any material new evidence that might lead you to change your decision. Decide whether your interpretation of the *rules* may have been wrong; be open-minded as to whether you have made a mistake. If none of these applies refuse to reopen; otherwise schedule a hearing.

M5 GROSS MISCONDUCT (rule 69)

M5.1 An action under this rule is not a *protest*, but the protest committee gives its allegations in writing to the competitor before the hearing. The hearing is conducted under the same rules as other hearings but the protest committee must have at least three members (rule 69.1(b)). Use the greatest care to protect the competitor's rights.

M5.2 A competitor or a board cannot protest under rule 69, but the protest form of a competitor who tries to do so may be accepted as a report to the protest committee, which can then decide whether or not to call a hearing.

M5.3 When it is desirable to call a hearing under rule 69 as a result of a Part 2 incident, it is important to hear any board-vs.-board *protest* in the normal way, deciding which board, if any, broke which *rule*, before proceeding against the competitor under this rule.

M5.4 Although action under rule 69 is taken against a competitor, not a board, a board may also be penalized (rule 69.1(b)).

M5.5 The protest committee may warn the competitor (rule 69.1(b)), in which case no report is to be made to national authorities (rule 69.1(c)). When a penalty is imposed and a report is made to national authorities, it may be helpful to recommend whether or not further action should be taken.

M6 APPEALS (rule 70 and Appendix F)

When decisions can be appealed,

- retain the papers relevant to the hearing so that the information can easily be used for an appeal. Is there a diagram endorsed or prepared by the protest committee? Are the facts found sufficient? (Example: Was there an *overlap*? Yes or No. 'Perhaps' is not a fact found.) Are the names of the protest committee members and other important information on the form?
- comments by the protest committee on any appeal should enable the appeals committee to picture the whole incident clearly; the appeals committee knows nothing about the situation.

M7 PHOTOGRAPHIC EVIDENCE

Photographs and videotapes can sometimes provide useful evidence but protest committees should recognize their limitations and note the following points:

- The *party* producing the photographic evidence is responsible for arranging the viewing.
- View the tape several times to extract all the information from it.
- The depth perception of any single-lens camera is very poor; with a telephoto lens it is non-existent. When the camera views two *overlapped* boards at right angles to their course, it is impossible to assess the distance between them. When the camera views them head on, it is impossible to see whether an *overlap* exists unless it is substantial.
- Ask the following questions:
 - Where was the camera in relation to the boards?
 - Was the camera's platform moving? If so in what direction and how fast?
 - Is the angle changing as the boards approach the critical point? Fast panning causes radical change.
 - Did the camera have an unrestricted view throughout?

APPENDIX N

INTERNATIONAL JURIES

See rules 70.4 and 90(b). This appendix shall not be changed by sailing instructions or prescriptions of national authorities.

N1 COMPOSITION, APPOINTMENT AND ORGANIZATION

- N1.1** An international jury shall be composed of experienced sailors with excellent knowledge of the racing rules and extensive protest committee experience. It shall be independent of and have no members from the race committee, and be appointed by the organizing authority, subject to approval by the national authority if required (see rule 90(b)), or by the ISAF under rule 88.2(b).
- N1.2** The jury shall consist of a chairman, a vice chairman if desired, and other members for a total of at least five. A majority shall be International Judges. The jury may appoint a secretary, who shall not be a member of the jury.
- N1.3** No more than two members (three, in Groups M, N and Q) shall be from the same national authority.
- N1.4** (a) A jury of ten or more members may divide itself into two or more panels of at least five members each, of which the majority shall be International Judges. If this is done, the requirements for membership of a full jury shall apply to each panel but not to the jury as a whole.
- (b) A jury of fewer than ten members may divide itself into two or three panels of at least three members each, of which the majority shall be International Judges. Members of each panel shall be from at least three different national authorities except in Groups M, N and Q, where they shall be from at least two different national authorities. If dissatisfied with a panel's decision, a *party* is entitled to a hearing by a jury composed in compliance with rules N1.1, N1.2 and N1.3, except concerning the facts found, if requested within the time limit specified in the sailing instructions.
- N1.5** When a full jury has fewer than five members, because of illness or emergency, and no qualified replacements are available, it remains

properly constituted if it consists of at least three members. At least two members shall be International Judges. When there are three or four members they shall be from at least three different national authorities except in Groups M, N and Q, where they shall be from at least two different national authorities.

- N1.6** When the national authority's approval is required for the appointment of an international jury (see rule 90(b)), notice of its approval shall be included in the sailing instructions or be posted on the official notice board.

- N1.7** If the jury acts while not properly constituted, the jury's decisions may be appealed.

N2 RESPONSIBILITIES

- N2.1** An international jury is responsible for hearing and deciding all *protests*, requests for redress and other matters arising under the rules of Part 5. When asked by the organizing authority or the race committee, it shall advise and assist them on any matter directly affecting the fairness of the competition.

- N2.2** Unless the organizing authority directs otherwise, the jury shall
- decide questions of eligibility, measurement or board certificates; and
 - authorize the substitution of competitors, boards, sails or equipment.

- N2.3** If so directed by the organizing authority, the jury shall
- make or approve changes to the sailing instructions,
 - supervise or direct the race committee in the conduct of the races, and
 - decide on other matters referred to it by the organizing authority.

N3 PROCEDURES

- N3.1** Decisions of the jury shall be made by a simple majority vote of all members. When there is an equal division of votes cast, the chairman of the meeting may cast an additional vote.

- N3.2** When it is considered desirable that some members not participate in discussing and deciding a *protest* or request for redress, and no qualified replacements are available, the jury remains properly constituted if at least three members remain. At least two members shall be International Judges.
- N3.3** Members shall not be regarded as *interested parties* (see rule 63.4) by reason of their nationality.
- N3.4** If a panel fails to agree on a decision it may adjourn and refer the matter to the full jury.

DEFINITIONS

A term used as stated below is shown in italic type or, in preambles, in bold italic type.

Abandon A race that a race committee or protest committee *abandons* is void but may be resailed.

Beach Start (B1.1) When the starting line is on the beach, or so close to the beach that the competitor must stand in the water to *start*, the start is a *beach start*.

Capsized (B1.1) A board is *capsized* when her sail or the competitor is in the water.

Clear Astern and Clear Ahead; Overlap One board is *clear astern* of another when her hull and equipment in normal position are behind a line abeam from the aftermost point of the other board's hull and equipment in normal position. The other board is *clear ahead*. They *overlap* when neither is *clear astern*. However, they also *overlap* when a board between them *overlaps* both. These terms do not apply to boards on opposite *tacks* unless rule 18 applies.

Finish A board *finishes* when any part of her hull, or crew or equipment in normal position, crosses the finishing line in the direction of the course from the last *mark*, either for the first time or after taking a penalty under rule 31.2 or 44.2 or, under rule 28.1, after correcting an error made at the finishing line.

Interested Party A person who may gain or lose as a result of a protest committee's decision, or who has a close personal interest in the decision.

Keep Clear One board *keeps clear* of another if the other can sail her course with no need to take avoiding action and, when the boards are *overlapped* on the same *tack*, if the *leeward* board can change course in both directions without immediately making contact with the *windward* board.

Leeward and Windward A board's *leeward* side is the side that is or, when she is head to wind, was away from the wind. However, when sailing by the lee or directly downwind, her *leeward* side is the side on which her mainsail lies. The other side is her *windward* side. When two boards on the same *tack*

overlap, the one on the *leeward* side of the other is the *leeward* board. The other is the *windward* board.

Mark An object the sailing instructions require a board to leave on a specified side, and a race committee boat surrounded by navigable water from which the starting or finishing line extends. An anchor line and objects attached temporarily or accidentally to a *mark* are not part of it.

Obstruction An object that a board could not pass without changing course substantially, if she were sailing directly towards it and one of her hull lengths from it. An object that can be safely passed on only one side and an area so designated by the sailing instructions are also *obstructions*. However, a board *racing* is not an *obstruction* to other boards unless they are required to *keep clear* of her, give her *room* or, if rule 21 applies, avoid her.

Overlap See *Clear Astern and Clear Ahead; Overlap*.

Party A *party* to a hearing: a protestor; a protestee; a board requesting redress; a board or a competitor that may be penalized under rule 69.1; a race committee or an organizing authority in a hearing under rule 62.1(a).

Postpone A *postponed* race is delayed before its scheduled start but may be started or *abandoned* later.

Proper Course A course a board would sail to *finish* as soon as possible in the absence of the other boards referred to in the rule using the term. A board has no *proper course* before her starting signal.

Protest An allegation made under rule 61.2 by a board, a race committee or a protest committee that a board has broken a *rule*.

Racing A board is *racing* from her preparatory signal until she *finishes* and clears the finishing line and *marks* or retires, or until the race committee signals a general recall, *postponement* or *abandonment*.

Room The space a board needs in the existing conditions while manoeuvring promptly in a seamanlike way.

- Rule**
- (a) The rules in this book, including the Definitions, Race Signals, Introduction, preambles and the rules of relevant appendices, but not titles;
 - (b) ISAF Regulation 19, Eligibility Code; Regulation 20, Advertising Code; and Regulation 21, Anti-Doping Code;

- (c) the prescriptions of the national authority, unless they are changed by the sailing instructions in compliance with the national authority's prescription, if any, to rule 87;
- (d) the class rules (for a board racing under a handicap or rating system, the rules of that system are 'class rules');
- (e) the notice of race;
- (f) the sailing instructions; and
- (g) any other documents that govern the event.

Start A board *starts* when, having been entirely on the pre-start side of the starting line at or after her starting signal, and having complied with rule 30.1 if it applies, any part of her hull, crew or equipment crosses the starting line in the direction of the first *mark*.

Tack, Starboard or Port A board is on the *tack*, *starboard* or *port*, corresponding to her *windward* side.

Two-Length Zone The area around a *mark* or *obstruction* within a distance of two hull lengths of the board nearer to it.

Windward See *Leeward and Windward*.

The following definitions apply only to expression competition (B1.2).

Coming In and Going Out A board sailing in the same direction as the incoming surf is *coming in*. A board sailing in the direction opposite to the incoming surf is *going out*.

Jumping A board is *jumping* when she takes off at the top of a wave while *going out*.

Overtaking A board is *overtaking* from the moment she gains an *overlap* from *clear astern* until the moment she is *clear ahead* of the *overtaken* board.

Possession The first board sailing shoreward immediately in front of a wave has *possession* of that wave. However, when it is impossible to determine which board is first the *windward* board has *possession*.

Recovering A board is *recovering* from the time her sail or, when water-starting, the competitor is out of the water until she has steerage way.

Surfing A board is *surfing* when she is on or immediately in front of a wave while *coming in*.

DEFINITIONS

Transition A board changing *tacks*, or taking off while *coming in*, or one that is not *surfing*, *jumping*, *capsized* or *recovering* is in *transition*.